



PRODUCT DESIGN FOR REEF RESTORATION

The design of a reef tile for the restoration of flat oyster reefs in the Dutch North Sea.

Summary

Keywords: restoration ecology, ecosystem ecology, *Ostrea edulis*, reef restoration, reef tile.

Because of human interventions in our seas, like commercial (over)fishing and the introduction of diseases, the presence and biodiversity of natural reefs is declining severely. Reefs provide a habitat for a variety of marine species and are of great value to marine ecosystems. Therefore, it is of importance to recover affected reefs.

Also in the Dutch North Sea, a majority of the reef has disappeared, including reefs of the European flat oyster (*Ostrea edulis*). Oysters in particular play a key role in reef ecosystems and are therefore the ideal starting point for the recovery of reefs in the Dutch North Sea.

There is no possibility that these oysters will naturally recover: they are not numerous enough to naturally breed and spread. Therefore, there is a need for active restoration. Several methods for restoration exist already, however, these are not proven to be effective and have several drawbacks.

Recently, marine biologists suggested a new method for the restoration of flat oyster reefs, where oyster larvae settle on a small product, which then gets sown in the ocean and naturally form oyster beds. However, this method is theoretical; no such product is developed yet. The goal of this graduation project is to develop this product: from conceptualization to embodiment to preliminary validation in laboratory settings. By the end of the project, the product is ready for field tests and will ultimately enable the restoration of reefs.

Literature review showed no reference model or design guide, as no such products exist yet. Therefore, ideation started with the exploration of basic shapes and their behaviour underwater. These basic shapes were altered in such a way to fit the purpose, whereafter several iterative steps concluded in five final concepts. A practical approach enabled quick iterations.

Simultaneously, exploration of bio-based materials suitable for an application underwater resulted in a material that meets requirements.

Two concepts were chosen and made into operational prototypes to test in laboratory settings. These tests, executed in a sediment flume, indicated the performance of the products in water flow. One of the two concepts was more successful in this simulated environment; this product is elaborated.

The final product promotes larvae settlement on the product and allows people to touch the product without touching settled larvae. The product sinks to the sea bottom and stays in place as much as possible, which entails resisting water flow up to 1.9 m/s. The design protects larvae against larger predators and makes sure they stay above the sediment. Finally, the product is large enough for a grown oyster and persists between six months and two years on the seabed, after which the naturally occurring material degrades into biologically safe components.

In conclusion, a product has been designed that can enable the restoration of oyster reefs. With this product, large areas of reef can be restored in an effective and minimally invasive manner.

As the indication of performance is only performed in laboratory settings, the advice is to validate in a relevant natural environment to improve knowledge about this product and method. These tests should clarify the performance of the product and the material.

TABLE OF CONTENTS

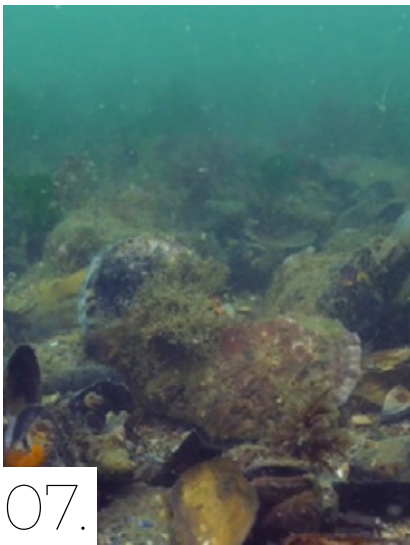

06.	1. Introduction Explanation of unfamiliar jargon.
09.	2. Assignment Explanation of the graduation assignment.
11.	3. Context Key developments leading up to the project.
14.	4. Method Planning and design phases.
17.	5. Analysis Background information and literature research.
37.	6. Main drivers Requirements for the design.
39.	7. Ideation Idea generation for a reef restoration product.
46.	8. Concepts Five concepts for a reef restoration product.
50.	9. Concept choice Choosing two concepts to test.
55.	10. Functional prototyping Prototypes of the two concepts.
59.	11. Functionality testing Flume experiments with two concepts.

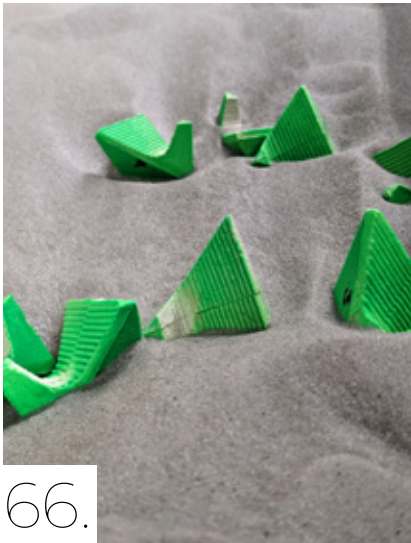

66.



80.

72.

12. Embodiment

Embodiment of the final concept.

76.

13. Product presentation

Interaction vision with the final product.

79.

14. Validation

Validate product against design criteria.

87.

15. Conclusions

Is the assignment fulfilled?

90.

16. Recommendations

What are further steps?

94.

17. Reflection and acknowledgements

Reflection using triple-loop-learning

98.

Glossary

Explanation of unfamiliar jargon.

100.

Bibliography

102.

Appendices



INTRODUCTION

An introduction to a graduation project about the design of a product for the restoration of flat oyster reefs in the Dutch North Sea.



Figure 1: A healthy oyster reef (photo: ARK Natuurontwikkeling).

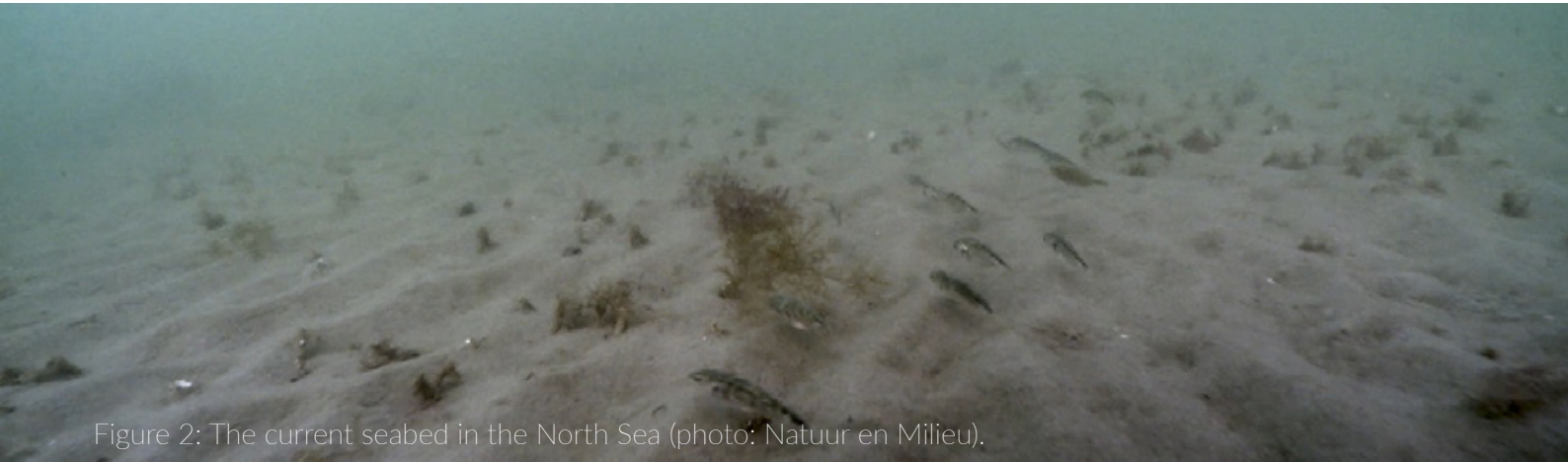

Figure 2: The current seabed in the North Sea (photo: Natuur en Milieu).

Because of human interventions in our seas, like commercial (over)fishing and the introduction of diseases, the presence and biodiversity of natural reefs is declining severely [1-3]. Reefs provide a habitat for a variety of marine species and are of great value to marine ecosystems [3]. Therefore, it is of importance to recover the affected reefs.

Also in the Dutch North Sea, a majority of the reef has disappeared, including reefs of the European flat oyster (*Ostrea edulis*) [2, 4]. Oysters, in particular, play a key role as the foundation of reef ecosystems and are therefore the ideal starting point for the recovery of reefs in the Dutch North Sea [5, 6].

However, current numbers of flat oysters in the Dutch North Sea are so alarmingly low that their status is considered to be 'critical': under immediate threat of extinction [2, 4, 7, 8]. The species has been functionally extinct

in the Wadden Sea already since 1940 [2, 8, 9]. The disappearance of the Dutch shellfish reefs is mostly due to overexploitation, habitat destruction, and diseases, which all can be linked to manageable human activities [5, 8-10]. There is no possibility for the oyster reefs to naturally recover: they are not numerous enough to naturally breed and spread [11]. Therefore, there is a need for active restoration [12-15].

Recently, marine biologists suggested a new method for the restoration of flat oyster reefs, where oyster larvae settle on a small product, which then gets sown in the ocean and naturally form oyster beds. This method is less invasive and is more suited for implementation on larger scales than existing reef restoration methods. There are possibilities for restoration around offshore wind farm sites, where it is prohibited to fish from the seabed, providing desirable circumstances for the restoration of reef [6, 9, 11, 16, 17].

However, the proposed method is theoretical; the product enabling this means of restoration is not yet developed. This thesis comprises the research, conceptualization, and embodiment of this product and preliminary validation in laboratory settings. This involved simulation tests indicating the product's behaviour on different sea beds, such as the gravel and sand bottoms of the North Sea, under different conditions (average flow rates, the annual storm). The project finished with a set of prototypes, ready to be produced 500-fold and tested in real conditions.

This report explains the workflow and major decisions about the design. It starts with an explanation of the assignment, project scope, and context. Then, the method used to achieve the final result is introduced. To have the necessary knowledge to start the design phase, a proper base of knowledge on flat oysters and reef-forming is described. After the description

of the requirements and main drivers of the project, ideation can be found: sinking and landing behaviour of basic shapes, relevant bio-based materials, and conceptualization. Next, the final concepts are presented and the choice of concept is elaborated. The experimental setup and results of the flume tests are discussed, followed by the final design. By that final design, the technology readiness level (TRL) of the product is raised from level one to level five. This report concludes with recommendations to raise the TRL further, so the restoration of flat oyster reefs in the Dutch North Sea gets one step closer.

Ultimately, all global reefs could be restored using this method, as the product could be used for other larvae of bottom-dwelling marine organisms (such as mussels, tube worms, anemones, and corals) as well, leading to numerous applications where this product can be used for marine ecosystem restoration.

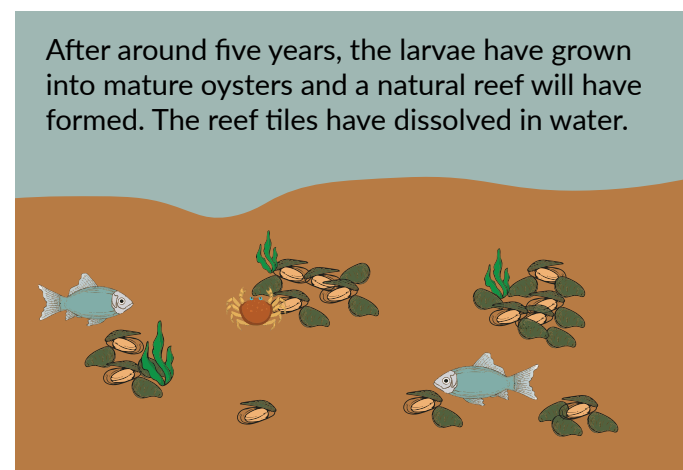
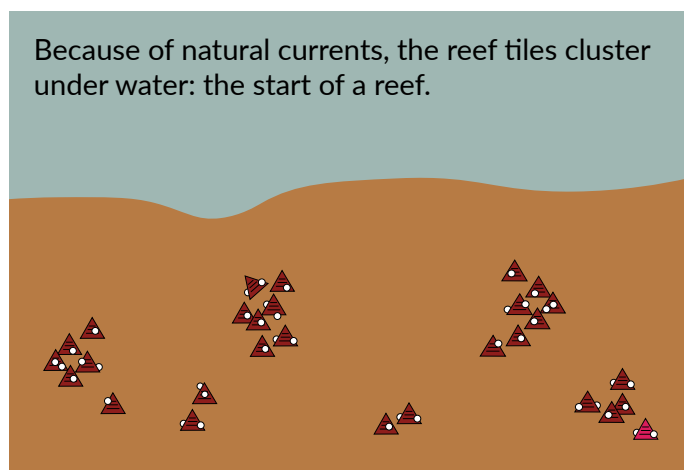
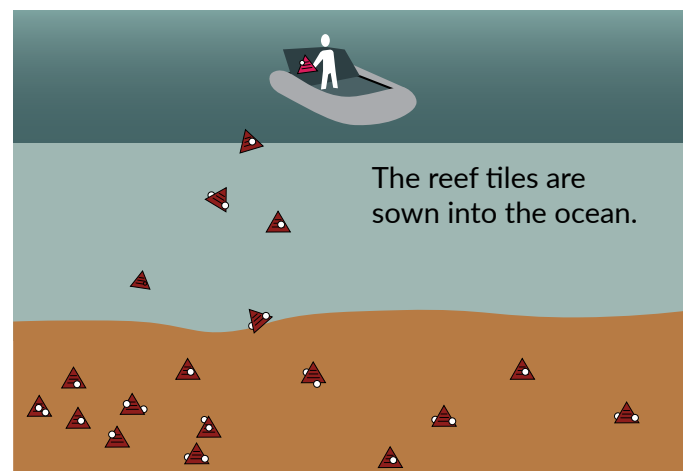
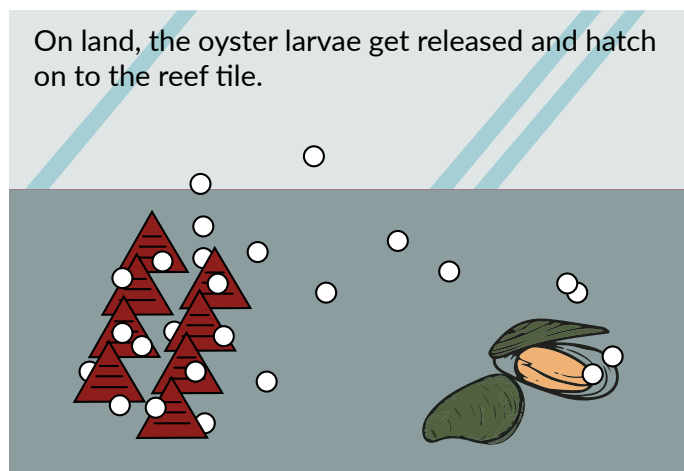

Figure 3: The method for reef restoration.



ASSIGNMENT

This graduation project's assignment is to enable restoration of flat oyster reefs in the North Sea by designing a product that promotes attachment of larvae of flat oysters and natural reef-forming when sown in water.

By means of this graduation project, I aimed to contribute to science by further developing the seeding method for reef restoration. The proposed method for restoration involves cultivating flat oyster larvae on land, letting the larvae attach to a product, also called a 'reef tile', transporting the 'reef tiles' to the desired location at sea, seeding the 'reef tiles' in the sea, and letting the tiles form a natural reef underwater, whereafter they degrade.

Ecological restoration is the process of assisting the recovery of an ecosystem that has been degraded, damaged, or destroyed [18].

The goal of this graduation project is to develop this product that is necessary for the seeding method: from research, to conceptualization, to embodiment, to preliminary validation in laboratory settings. The scope of this project can be found in figure 4. A thought-through design of the 'reef tile' was needed, to make this product easy to manufacture, transport, and use. The clutching potential, survival optimization, and proper landing were tested in laboratory settings. The project finished with a looks-like-real and works-like-real set of prototypes, so the product is ready for field tests and will ultimately enable the restoration of reefs. The full project brief can be found in Appendix 1.

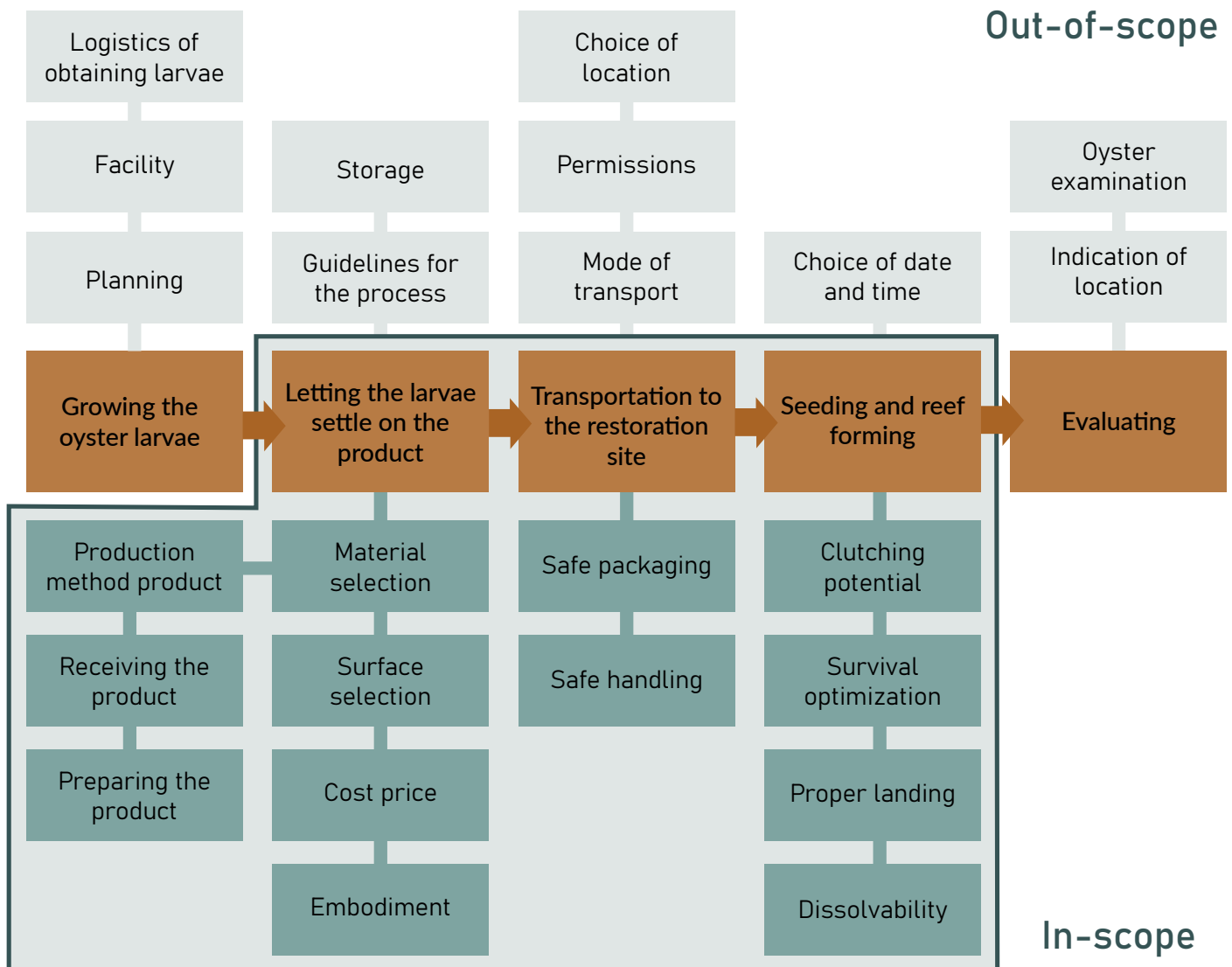

Figure 4: Scope of the graduation project.



CONTEXT

Due to human activities, almost all global reefs have declined severely [1]. With the goal of making an ecologically relevant impact, Blue Linked, a small company with experience in marine nature restoration projects, has proposed a novel method to restore these reefs: sowing out reef-building organisms on a small product. This product is being designed in this graduation project, in association with Blue Linked (client), Stichting De Rijke Noordzee (funding party), and the Delft University of Technology.

During my childhood, where I grew up on the island of Aruba, I had seen numerous fish and several types of corals on the reefs that surround the island. It felt like a given that these reefs were present; they existed there and would be there forever. However, as I grew older, it became clear to me that the presence of coral reefs is not as evident as I thought. Even worse, the presence of all reefs is declining fast. Because of this background, I became interested in corals and their restoration and wanted to contribute to the solution by dedicating my graduation project to this topic.

Coral experts at Wageningen University recommended me to approach Blue Linked; the idea of a 'reef tile' for the restoration of coral

reefs was founded at this company. Moreover, the method could be used for any marine organism that is a larva in its juvenile stage, as is the case with flat oysters. This project matched my interests on both an academic and personal level, feeling that the help of an industrial design engineer could elevate the project and increase its success.

This project was not in the executive stage, but as this collaboration increased the growth potential, Blue Linked decided to initiate the start of this project. At this point, there already was a first tangible idea (figure 6), but no ideas on how to continue or how to materialize.

Main stakeholders



First of all, the project's client: Blue Linked. This small company, owned by marine biologist Michaël Laterveer, aspires to improve marine ecosystems. They pitched the idea for reef restoration using 'reef tiles' around 2005. They have done several projects on marine nature restoration and are also involved in circular fish farming, and can therefore provide me with knowledge on the biological aspects of the project. They expected me to improve their idea for the 'reef tile' up to a point where the product could be used for a validating field test, therefore, large decisions are made in consultation. They do not have any product design skills in-house, therefore I can add value to this company.



Stichting De Rijke Noordzee finances Blue Linked's project. They have the goal to restore biogenic reefs in the North Sea, as partners of the Dutch Ministry of Agriculture, Nature, and Food Quality, and believe this project could be a way to achieve this. Every three weeks there was an update and feedback session together with Blue Linked, De Rijke Noordzee, and me, where they also provided me with data on their (restoration) practices.



K&S Décor, a small company owned by René Smeets, made the first physical idea and can be seen as a critical friend in this context. They have been involved since the pitch of the idea for the 'reef tiles' and are interested in contributing to reef restoration. With the background of being a set designer, they are available for design and materialization feedback.

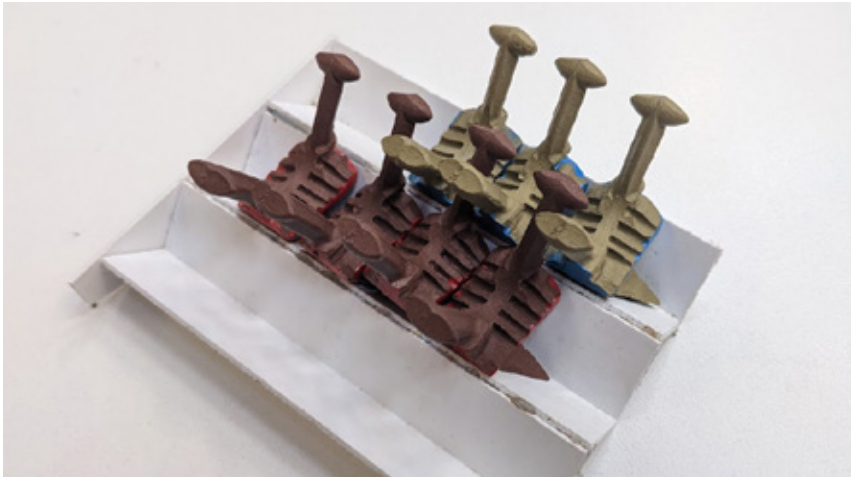

Figure 5 (left): The existing prototypes in their tray. Figure 6 (right): A prototype of the existing design.



The TU Delft is also involved in this graduation project, as the institution wants me to showcase that I have the skills to call myself an industrial design engineer. They set some boundary conditions for this project, including a maximum timeline of one hundred working days and mandatory publication of academic graduation work. The TU Delft's ambition is to solve global challenges by training new generations of socially responsible engineers [19]. This project contributes to solving a global challenge, as one of the few projects at IDE revolving around the restoration of ecological systems. The institution is being represented by my chair and mentor.

In conclusion, the main stakeholders, Blue Linked (client), Stichting De Rijke Noordzee (funding party), and the Delft University of Technology share a common ambition: solving a global challenge, reef restoration in this case. They have different expectations, Blue Linked and De Rijke Noordzee being more result-based, while TU Delft's expectations are more process-based, so managing expectations could be challenging.



METHOD

The research method used for this design project is based on the double-diamond model. This can be linked back to five phases this project is divided into: 1. Discovering and Defining, 2. Developing, 3. Demonstrating, 4. Delivering, 5. Reporting and Presenting.

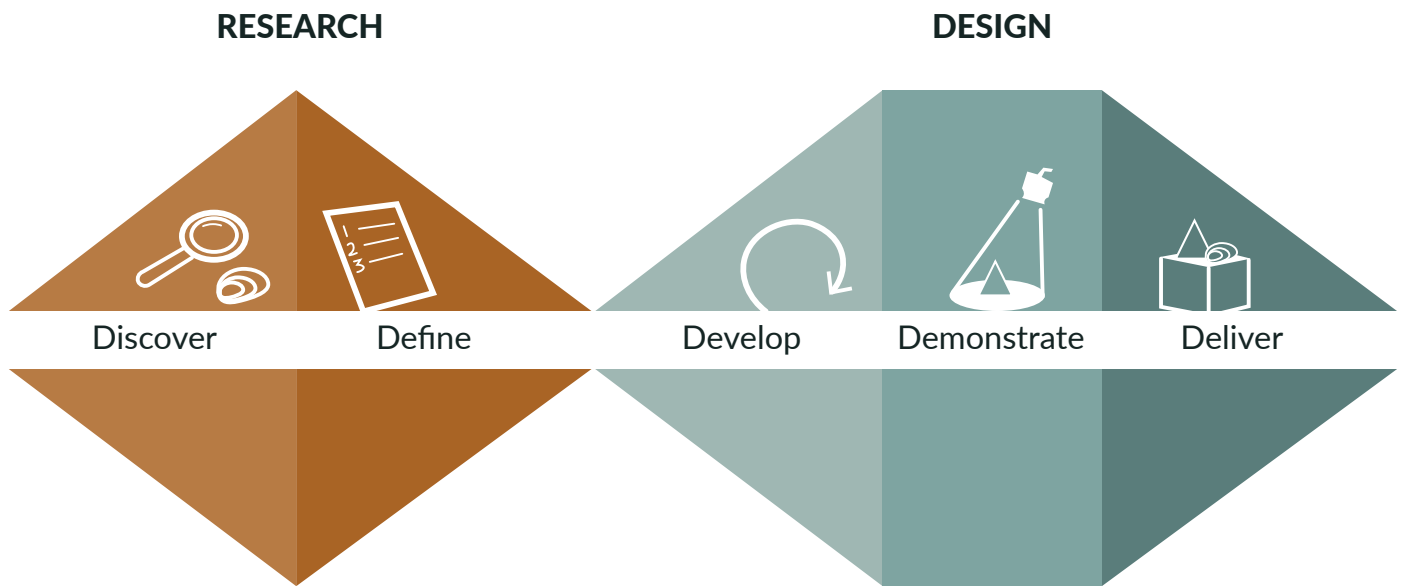

Figure 7: The Double Diamond process.

The Double Diamond design process, created by the Design Council, serves as a suitable example of a standardized design method [20]. This method was chosen, as it allows for exploring in a wider sense and uses that exploration for taking substantiated and focused action. Given that there are no design guides or reference models for this context and problem, a wider exploration is beneficial to the design. Therefore, in my opinion, this method is suited best.

The double diamond is formed from four distinct phases: Discover, Define, Develop, and Deliver. I added an extra part to the existing model: Demonstration. A planning was made based on these phases; this can be found in Appendix 2.

The 'Discover' phase is also being referred to as the *fuzzy front end* and was about defining the nature of the problem that the design addresses. Background research was being done here, with the goal to end with a proper base of knowledge on flat oysters and reef-forming.

This involved, firstly, a literature review to support evidence-based practice and guide the decision-making, to be used in the 'Define' phase. Relevant literature was searched systematically using keywords that occur in the sub-questions, like 'reef restoration', 'Ostrea edulis', or 'oyster settlement substrate', and cross-references. The selection was based on title or abstract; after reading the introduction and conclusion a possible fit to the research question was determined.

Secondly, open interviews with experts on ecosystem restoration and off-shore engineering allowed for acquiring the most in-depth information, as I had no prior knowledge on these topics.

In the 'Define' phase, the goal was to make sense of the findings from the 'Discover' phase, understanding what the main drivers of the problem were. Based on these insights, the utility of the design assignment was proven and a list of requirements for the design was defined. This phase is convergent.

The 'Develop' phase concentrated on developing and trying out multiple potential solutions, also called conceptualization. This phase is iterative, which means the process was repeated until satisfied with the design. A practical approach enabled quick iterations. The goal of this phase was to present between three and five concepts that could be tested: at least two concepts derived from conceptualization, and one being the existing embodiment of the 'reef tile'. Two concepts were chosen using the 'weighted objectives' method and prototyped 30-fold. Also, a final material was chosen that met requirements. This phase is divergent.

In the 'Demonstrate' phase, the goal was to demonstrate how the concept meets requirements. The stability and interaction underwater were demonstrated in flume experiments. The product lifetime could be calculated, and the other design criteria could be held against literature findings. Full validation is only possible after field experiments, so these demonstrations only indicate whether meeting design criteria is feasible.

The 'Deliver' phase involves selecting a final design, so being convergent. The results of the tests in the 'Demonstration phase' were used to choose one of the concepts to detail and to elaborate on. The choice for the final design was made in consultation with Blue Linked, based on the design criteria. The goal was to end with a final design that can be used for testing in the North Sea.

Finally, this project ended with a finished report and a presentation on this graduation project. The goal of this phase was to show the workflow and major decisions leading to the final design.





ANALYSIS

This analysis, also being called the 'Discover' phase, is about defining the nature of the problem that the design addresses. Background research was being done here, with the goal to end with a proper base of knowledge on flat oysters and reef-forming, which is necessary to start the design phase.

This involved, firstly, a literature review to support evidence-based practice and guide the decision-making. Relevant literature was searched systematically using keywords that occur in the sub-questions, like 'reef restoration', 'Ostrea edulis', or 'oyster settlement substrate', and cross-references. The selection was based on title or abstract; after reading the introduction and conclusion a possible fit to the research question was determined.

What is 'a proper base of knowledge'? For this project, that is a set of relevant questions that should be answered. The goal was to get to know the system we are working in. Firstly, on a mega-level: what is a flat oyster reef? Secondly, on a macro-level: why should flat oyster reefs be restored? Thirdly, on a meso-level: how does oyster reef restoration work in the North Sea? Fourthly, on a micro-level: what are the preferences of oysters within the North Sea?

Secondly, open interviews with experts on ecosystem restoration and off-shore engineering allowed for acquiring in-depth information, as I had no prior knowledge on these topics. An expert on off-shore engineering could share their knowledge on water current tests, so I could discuss with them, use their advice, and plan a test.

Flat oyster reefs

- a. What is a flat oyster?
- b. What do flat oyster reefs look like, currently?
- c. What would flat oyster reefs look like, ideally? (endpoint ecosystem?)
- d. Why are flat oyster reefs not in their ideal state?

Flat oyster reef restoration

- a. Why are flat oyster reefs of importance?
- b. Why should we do restoration of flat oyster reefs?
- c. What are existing guidelines for (flat oyster) reef restoration?
- d. How to evaluate the performance of a restoration method?
- e. What is the vision for the 'reef tile'?

Flat oyster reef restoration in the Dutch North Sea

- a. What is the scale of the needed reef restoration?
- b. What conditions are present in the Dutch North Sea?
- c. What are the regulations for flat oyster reef restoration in the Dutch North Sea?
- d. What are existing efforts for flat oyster restoration in the Dutch North Sea?
- e. What is the impact of existing efforts for flat oyster restoration in the Dutch North Sea?

Settlement preferences of flat oysters, in order to do reef restoration in the Dutch North Sea

- a. How does settlement work naturally?
- b. What is the preferred alternative substrate?
- c. What is the preferred type of surface?
- d. What are other useful conditions for larvae settlement?

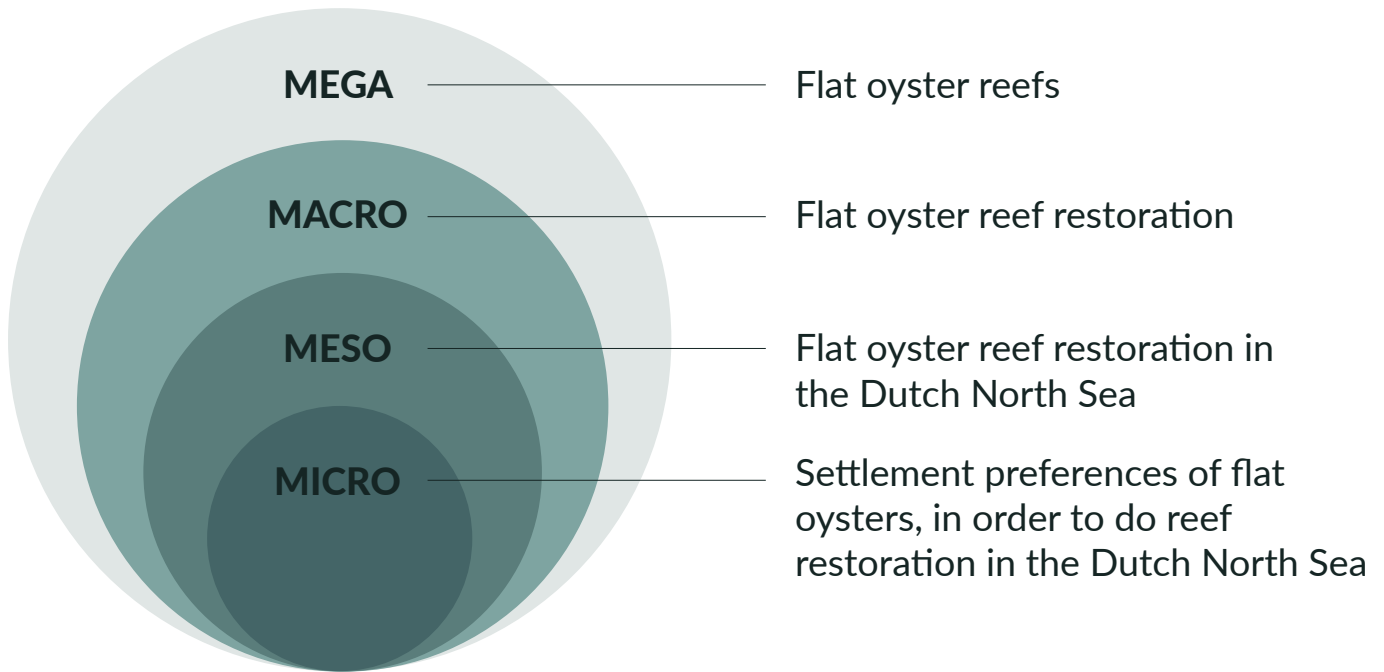
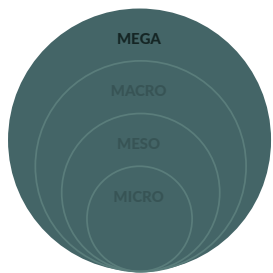

Figure 8: The four levels of research.



What does a flat oyster reef look like?

What is a flat oyster (*Ostrea edulis*)?

As the European flat oyster is the subject of our design, it is useful knowing what type of organism we are designing for.

The *Ostrea edulis*, also commonly called the 'flat oyster' or the 'European oyster', is an oyster native to the North Sea. It can also be found naturally in the Norwegian Sea, down to the Iberian Peninsula and the Atlantic coast of Morocco, the Mediterranean Sea, and extending into the Black Sea [21].

Flat oysters can grow up to be ten centimeters long, rarely larger. However, size and shape can be extremely variable depending on conditions. Oysters, including European flat oysters, are bivalves; the two shells are also called valves. The shell is oval- or pear-shaped with a rough, scaly surface. The animal inside has a muscle to close and open the two valves; it is attached to both of the shells (with mantle tissue). It has gills

to take up oxygen and filter food from the water; oysters are filter-feeders [21].

These oysters start their life as a male, after around three years they are ready to reproduce and become able to switch between sexes (protandrous hermaphrodite). As a male, they spawn sperm, whereafter the oyster becomes a functional female. After fertilization, the eggs inside the mantle cavity are released after seven to ten days. The released larvae (~0.3mm) stay in the water and search for a suitable substrate to settle upon.

Once settled, the oyster (spat: ~5mm) 'cements' itself to the substrate. As their choice of settlement is definitive, oysters have a relatively stationary existence (sessile) [21]. After one to two years, the mature *Ostrea edulis* has a length of around 50 millimeters.

Oysters, like several other marine benthic invertebrates, are gregarious settlers: they prefer to settle close to adult conspecifics. By doing so, they increase their likelihood of successful fertilization and increase the likelihood that they settle in an area with favourable environmental conditions [22].



Figure 9: Two open *Ostrea edulis* (photo: Marcel van den Bergh / de Volkskrant).

Main takeaways to base the design criteria on:

- The product should be large enough for a grown oyster of five centimeters long;
- The product should enable oysters to have access to flowing water, as this is how they feed;
- The product should provide oysters with a suited orientation, as oysters cannot move or switch substrate after settling.

What do flat oyster reefs look like, currently?

It is useful to know what the current conditions of the ecosystem are, as these influence the final deployment environment and the scale of the application.

Globally, more than 85% of oyster reefs have been lost [4]. Human-induced pressures have destroyed oyster banks in the Dutch North Sea up to a point close to extinction [7, 8]. Flat oyster banks currently only exist in estuaries

around the North Sea (e.g. Limfjorden in Denmark, Lake Grevelingen and Oosterschelde in the Netherlands) [9]. See figure 11 for an impression of these oyster banks.



Figure 10: An *Ostrea edulis* on the sea bed.



Figure 11: A flat oyster reef (Photo: Dutch Maritime Productions).

What would flat oyster reefs look like, ideally?

As the goal is to use design to bring back oyster reefs to a healthy stage, it is important to know what a healthy reef looks like.

A healthy flat oyster reef is a self-sustaining ecosystem with associated species present. It is resilient, structurally and functionally [18].

An ideal oyster reef ecosystem looks like its condition before degradation, which is before 1850 [18, 23, 24].

Abiotic ecosystem characteristics:

A1 physical state characteristics

- Water depth: +1 to -80 m deep [21]
- Sediment structure: firm silty sand, silty gravel with shells, rocks, sand smaller than 210 μm [21, 25]
- Water temperature: 3-30 $^{\circ}\text{C}$ [25]
- Flow speed: 0.25-0.8 m/s [21, 25]
- Bottom movement: <0.8 cm/day [25]
- Bed shear stress: 0.25-1 N/m² [25]

A2 chemical state characteristics

- Salinity: 20-35 % [25]
- Oxygen: >1.5 mg/L [25]
- Suspended matter content: 0-180 mg/L [25]

Biotic ecosystem characteristics:

B1 Compositional state characteristics (composition/diversity of ecological communities)

Oyster reefs form a resting and spawning area for fish such as plaice, cod, and sea bass. In their turn, they attract sharks, rays, porpoises, and seals. The shells provide a hard substrate where for instance dead men's thumb, a soft coral, can settle. Sharks, rays, smaller fish, and also the common cuttlefish can attach or deposit their eggs. In addition, all kinds of birds forage on the many small fish and shrimp that live on and around the shellfish bed [16]. Oysters enrich the sediment by their feeding process, which can increase seagrass growth [26].

B2 Structural state characteristics (aggregate properties)

The beds naturally occurred in the North Sea with densities of 5 or more per m² seafloor [8]. Total reef size used to be 25.000 km² in the Dutch North Sea [27]. Flat oysters are non-migratory [21].

B3 Functional state characteristics (biol. interactions)

The beds provide reproduction and genetic diversity for themselves, as there are other oyster beds within proximity. Reproduction occurs from June to September. Oysters of all ages occur (0-10 yr.) [21].

Main takeaways to base the design criteria on:

- The product should be stable in flow velocities up to 0.8 m/s, the same as oysters;
- The material should withstand water temperatures between 3-30 $^{\circ}\text{C}$;
- The material should withstand water salinity percentages of 20-35%.

Why are flat oyster reefs not in their ideal state?

The reason for the decline and current threats of oyster reefs are important to investigate, as these might influence the success of the 'reef tile', and could be mitigated.

The disappearance of the Dutch shellfish reefs is mostly due to overexploitation, habitat destruction, and diseases, which all can be linked to manageable human activities [5, 8, 10].

Destructive harvesting, like bottom trawling, and overfishing have reduced the habitat extent of oyster reefs [5]. The extensive harvesting continued until oysters could no longer be fished commercially [10]. By importing foreign oysters into our seas, microbial pathogens and parasites were introduced [8].

Other anthropogenic factors, such as hydrographic changes like the closure of the southern Zuiderzee, alterations of shorelines, and increased loadings of sediments, nutrients, and toxins have also likely played a role [10]. But, also natural causes, like the severe winters in the 1930s and 1940s, have played a role in their decline in the North Sea [8]. The same main reasons apply for their decline elsewhere in the world.

Main takeaways to base the design criteria on:

- The product should be able to be used on as many sediment types as possible; to be placed outside of areas where oyster habitat could be destroyed.

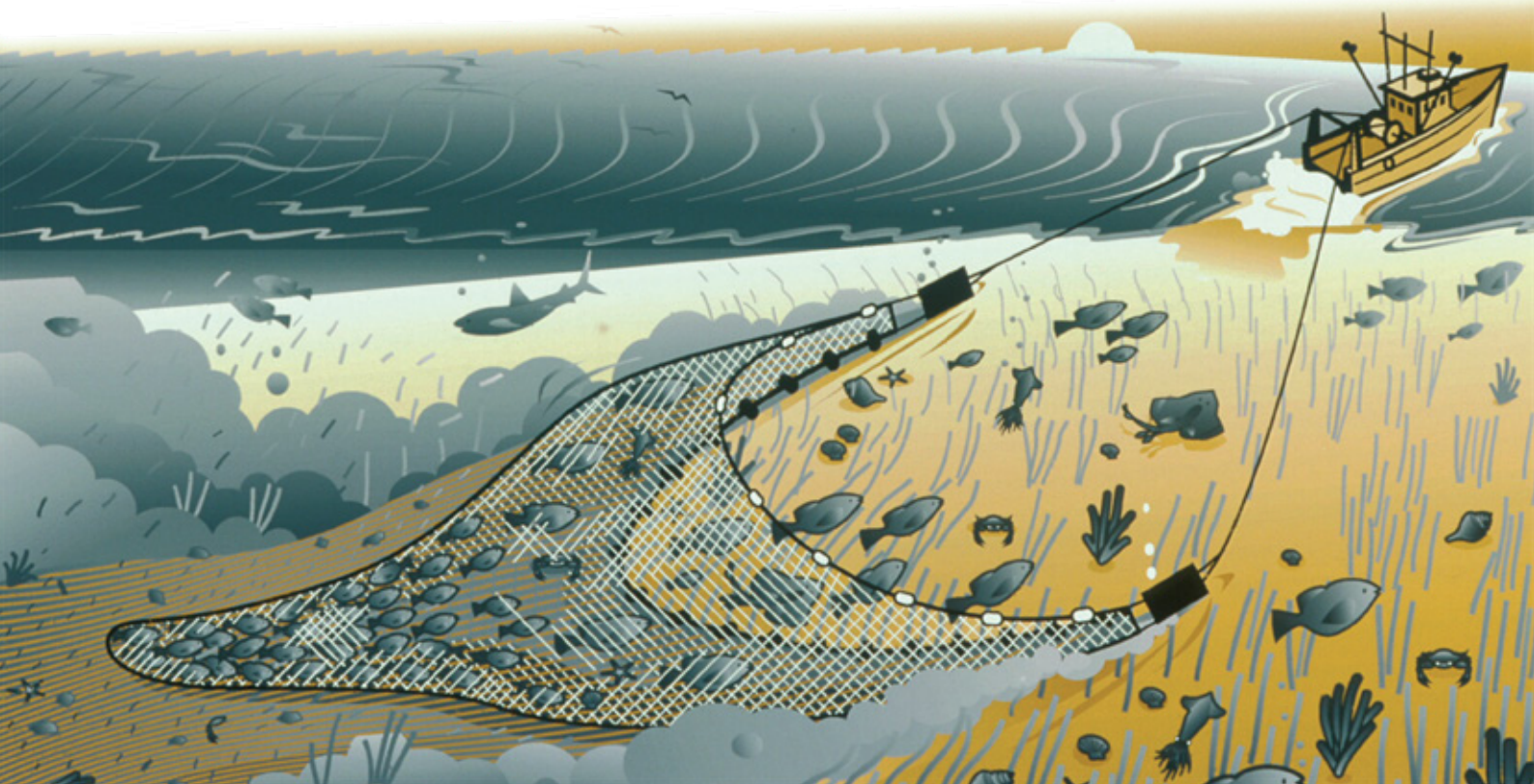
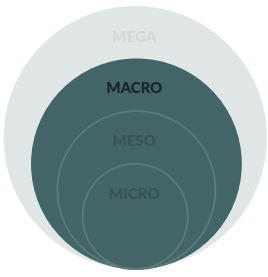

Figure 12: Destruction by bottom trawling (sketch: UNEP).



Why restore flat oyster reefs?

Why are flat oyster reefs of importance?

Their degree of importance shows the need for a restoration product.

Oyster reefs increase biodiversity and ecosystem functioning

Oysters are ecosystem engineers: they produce a habitat for entire ecosystems [28]. By creating (complex) three-dimensional structures with their shells, they provide refuge to other species, through the creation of microhabitats. This serves as a nursery ground for small species, provides protection, and the shells function as settlement substrates for other species [9]. On shellfish reefs there is greater food availability, resulting from the deposition of particles, which is beneficial for juvenile fish, crustaceans, and other organisms [29]. The number and abundance of other species found on shellfish reefs exceed those found in sandy sediment habitats [9].

The role of *Ostrea edulis* beds in the ecology of marine communities has led to it being

considered a keystone species (e.g. [5]). Declines in oyster reefs are therefore also linked to broader drops in coastal biodiversity [2, 30]. Hence, it is important to have healthy oyster populations, not only for the survival of oysters themselves but also for their associated fauna [8].

Oyster reefs provide ecosystem services

Ecosystem services are the benefits to humans, provided by the natural environment. Oyster reef ecosystems have irreplaceable cultural, societal, and economic value, in addition to their intrinsic value. Native ecosystems are more resilient, which is needed in times of natural disasters and climate change [31]. Oysters enhance water quality, provide habitat for fisheries species (e.g. fish and crustaceans), and reduce shoreline erosion [5, 30].

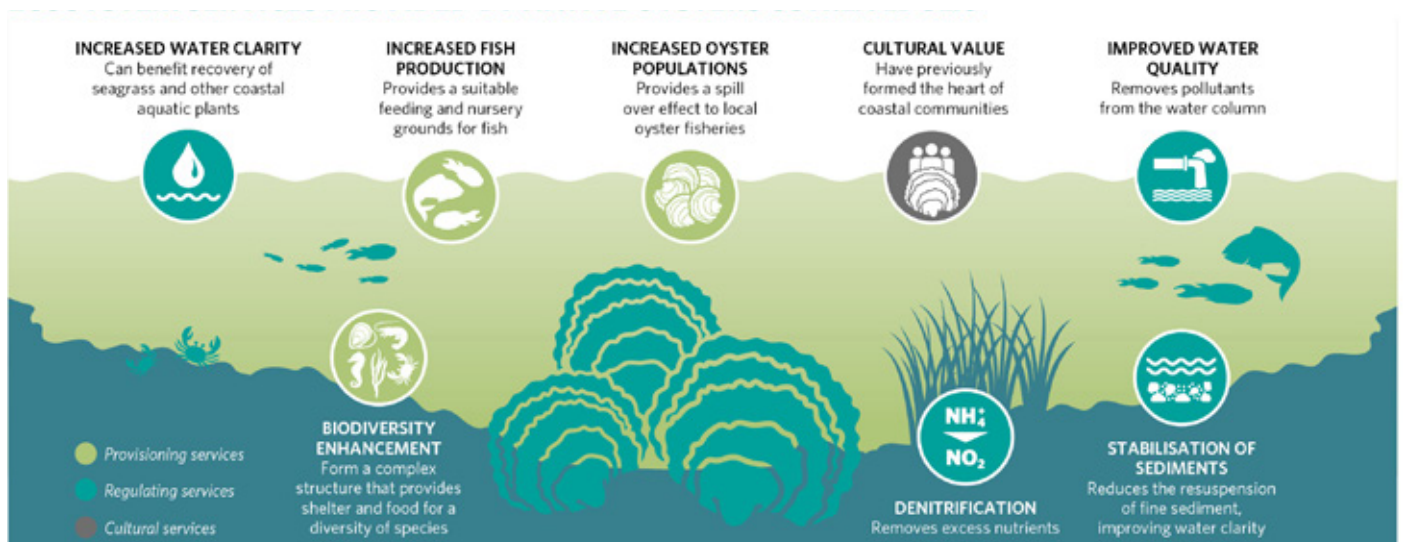

Figure 13: Ecosystem services provided by native oysters (image: Native Oyster Restoration Alliance).

Why should we do restoration of flat oyster reefs?

The answer to this question motivates the need for a restoration product aimed at flat oysters.

Oysters, in particular, play a key role as the foundation of reef ecosystems and are therefore the ideal starting point for the recovery of reefs in the Dutch North Sea [5, 6].

However, due to extremely low oyster densities and the absence of suitable substrate, the oyster banks cannot recover themselves [12-15]. Therefore, protection (passive restoration) is not sufficient and active restoration is needed [9, 12-15].

Ostrea edulis beds are identified as a priority marine habitat to protect in Europe, and current Dutch and EU government policy is supporting shellfish reef restoration in the North Sea [8]. In the Netherlands, the recovery of epibenthic shellfish reefs is estimated as feasible [9].

What are the existing guidelines or recommendations for (oyster) reef restoration?

It is useful knowing whether there are existing guidelines, as this increases the possibility for success and prevents us from making avoidable mistakes.

There are many recommendations for reef restoration in general; in this part, I will only focus on the ones that are relevant for the design of the product (e.g. no recommendations for site selection, monitoring, or funding).

Van Duren et al. (2016) set up relevant criteria that were used for other projects on North Sea Eco Restoration, see the list below [6]. These were made commissioned by the Dutch government, so by following these, there is a higher chance of success in acceptance of the project.

- Know the system you are working in [29];
- Focus on species and structures that occur naturally in the Dutch North Sea;
- Let nature do the work as much as possible;
- Minimize the need to use foreign material;
- Reduce the chance of introducing exotics*;
- Place oysters within proximity of each other[29];
- Formulate clear objectives and evaluate them effectively.

*One can minimize the chance of introducing exotics by executing the project in deeper parts of the sea, instead of shallow parts [6].

Main takeaways to base the design criteria on:

- The product's material should be as natural as possible;
- The products should discourage the introduction of exotics as much as possible.

How to evaluate the performance of a restoration method?

Evaluation methods could lead to specific criteria for the product. However, the evaluation of the method is out of this project's scope and will therefore not be taken into account for the design criteria, as decided in consultation.

What is the vision for the product?

The vision influences the design and appearance of the 'reef tile'.

We want to improve the ecological condition of global reefs, by providing an ecosystem engineer (range of benthic organisms) and letting nature do the rest of the (restoration) work. This approach should work for all benthic ecosystem engineers. Ultimately, this product can be used for the restoration of all types of reefs, from corals to oysters.

The primary motivator for designing this product is to make an ecologically relevant (positive) impact on reducing the (human-induced) degradation of local, regional, and global environmental conditions.



Figure 14: A healthy coral reef on Aruba (image: Jim Thompson)

Main takeaways to base the design criteria on:

- The product should allow for minor changes to suit other benthic organisms as well.

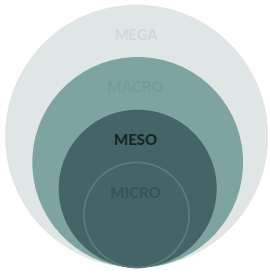

How does oyster reef restoration work in the Dutch North Sea?

What is the scale of the needed flat oyster reef restoration?

It is important to know the scale, as the number of products influences the cost price, production methods, transport requirements, and design.

From historical documentation, we know that reefs of flat oysters once occupied about 30% of the Dutch part of the North Sea bottom, approximately 25.000 km² in the 19th and early 20th century [27]. Currently, the species is considered to be practically extinct in the Dutch North Sea [8]. Therefore, it seems unrealistic to expect a fast recovery, but within ten to twenty years it should be feasible to avert the risk of extinction [4, 32].

The goal of this project is to increase oyster populations in the Dutch North Sea. We want to set the foundation for at least one oyster reef existing of minimally five mature oysters per square meter, within three years. A secondary goal is to validate the restoration method.

Thought experiment

Existing Dutch wind farms (Egmond aan Zee, Prinses Amalia, Luchterduinen, and Gemini) take up to around 133 square kilometres, which is only 0,23 per cent of the Dutch North Sea [33]. If we want to fill all wind parks with an oyster rate of 5 per m², we would get 665.000.000 oysters. Imagine that between 5-15% of oyster spat survives [34, 35]; then ~4.330.000.000 spat needs to be set out to reach the wanted oyster rate. The amount of settled spat on our product is to be determined, but roughly one in six spat survives, so having an average of six spat per product would be ideal. This leads us to around 720.000.000 products for only the Dutch North Sea wind parks. Imagine the amounts needed for global reef restoration...

Gemini alone is around 68 km² (roughly half of the total area), so following the same logic as stated above, we would need 360 million products. However, oysters could procreate themselves as well, so when seeding roughly one-third of the area and expecting the other two-thirds to naturally form (no reference for this out-of-the-blue number) we would need 120 million products. Just to get a feeling for the amounts.

Main takeaways to base the design criteria on:

- The product should be suited to be produced in amounts of hundreds of millions.

What conditions are present in the Dutch North Sea?

The Dutch North Sea will be our environment of use, therefore the characteristics need to be known to make sure our product will withstand this environment.

The types and size of sediment get determined by local currents. The main type of sediment in the Dutch North Sea is sand and silt.

Ostrea edulis does not like coarse sand (>210 μm). They like firm silty sand, silty gravel, and shells and stones best. This is because silt can often be found in sheltered places [36].

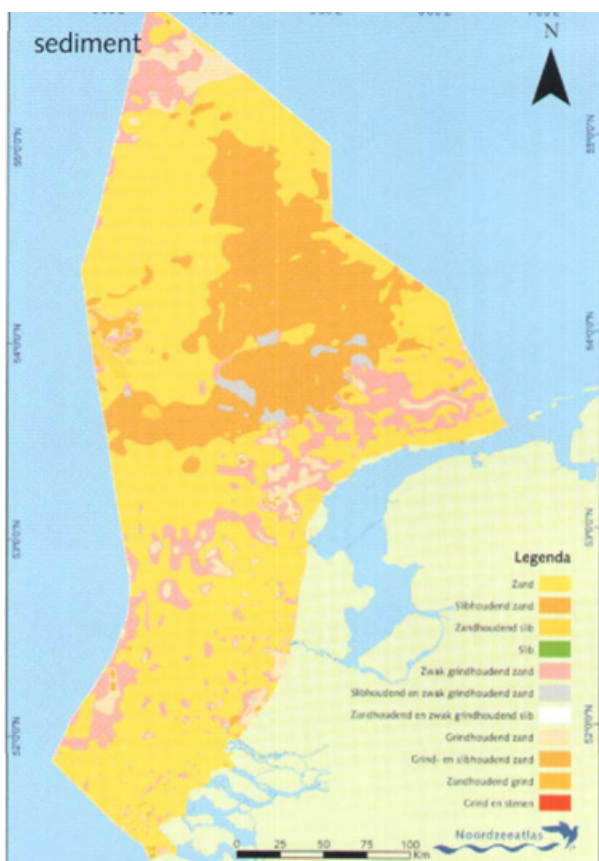

Main takeaways to base the design criteria on:

- The product should withstand temperatures between 5-20 °C.

What are the regulations for flat oyster reef restoration in the Dutch North Sea?

If the 'reef tiles' will be sown in the Dutch North Sea, they should conform to regulations. Therefore, it is of importance to know what regulations there are.

A legal exploration conducted by Van Benthem & Keulen (2020) commissioned by De Rijke Noordzee showed regulations regarding the placement of nature restorative structures in the North Sea [37].

It would be best if placing artificial reefs and substrates in the North Sea is not subject to a permit requirement, as that means there is no clean-up obligation. Whether or not a permit is required is mainly dependent on two things.

In the first place, some substances may not be landfilled without a permit (Article 6.3 of the Water Act). Whether artificial reefs and substrates can be regarded as such will depend on the precise composition of the material to be used and its impact on the environment. This can be determined by an ecological test. However, there is hardly any jurisprudence that provides guidance about the specific materials that fall under this act. Among other things, inert inorganic geological material, organic material of natural origin, and large items are named as materials that need a permit. No specific further explanation is given.

Secondly, the installation of artificial reefs and substrate should be in accordance with the function of the North Sea (and is therefore not subject to a permit requirement under Article 6.5(c) of the Water Act). Here too, the ultimate answer depends to a large extent on the answer to the question of what the effect is on the environment and whether this placement has no consequences for the safe and efficient functioning of the North Sea.

In the case a permit is required, the permit is only valid for a certain period. Article 15 Offshore Wind Energy Act shows that the absolute maximum timespan is 30 years. After this, the water body must be returned to its original state if this is reasonably possible (Article 6.8 Water Regulation). Whether it is reasonably possible is dependent on the size, composition, and properties of the substrate material.

Main takeaways to base the design criteria on:

- The product should have a material composition that is as natural as possible;
- The product should have as little effect on the environment as possible;
- The product should enable the water body to return to its original state within thirty years.

What are existing efforts for oyster reef restoration in the Dutch North Sea?

It is useful to know the existing efforts, so successful properties could be copied and characteristics that do not work can be prevented.

There are roughly three categories: placement of suitable substrate, the placement of living oyster stock, and the placement of both at the same

time. The latter is the most used method. The substrate that is generally used is waste shells [38-40].

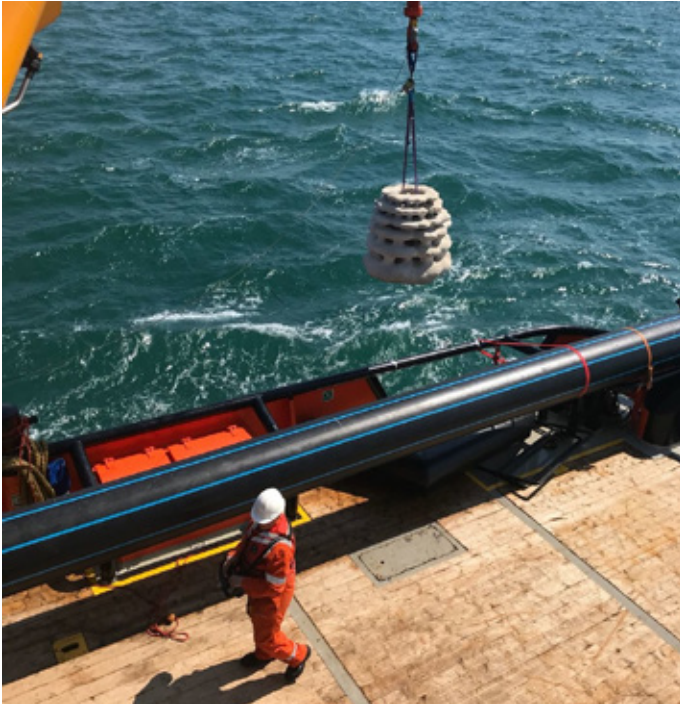

Figure 17 & 18: Sandstone structure before and after (photos: Udo van Dongen / Bureau Waardenburg).

80.000 flat oysters in cages were placed on Borkumse Stenen in 2018, and placement of shells as substrate (figure 20). Survival percentage between 32-92%. No significant settlement of larvae (four larvae) [38].

A reef dome with 30 mature oysters glued to it was placed at Blokkendam in 2018 (figure 21). Survival of 40-60%, no new settlement or growth [39].

Eight 3D-printed sandstone structures of 1,5 meters high with oysters epoxied onto them were placed on Borkumse Stenen in 2018 (figure 17). This project had around 32% survival. No significant settlement of larvae, as only one larva settled [41].

Cages with 600 live oysters were placed at Eneco Luchterduinen wind farm (IJmuiden). The goal was to find preferences of larvae for a specific substrate (cages with granite, shells, marble, silex). Survival of oysters at around 14%. No results on the experiment as all oysters and substrates got covered with sand [39].

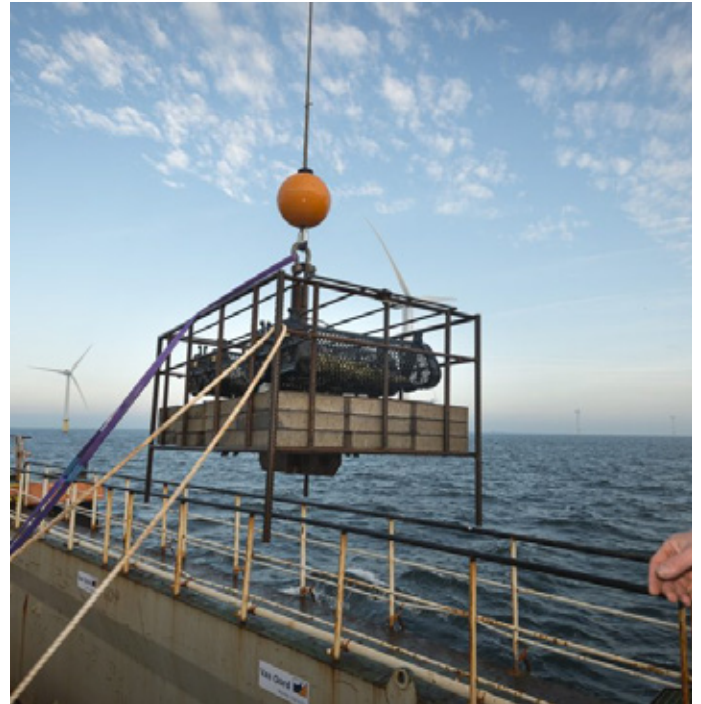

Figure 19 & 20: Placing shell substrate and oyster cages (photos: ARK Natuurontw. & Bureau Waardenburg).



Figure 21 & 22: A reef dome and reef blocks (photos: De Rijke Noordzee).

What is the impact of existing efforts?

It is useful to know the impact of existing efforts if we want to be able to compare our method.

There is no significant impact. All Dutch restoration projects have low survival rates and insignificant settlement rates of larvae, therefore, we do not consider them as successful [38-40]. Besides, large quantities of mature oysters are needed, which either need to be taken from existing natural stock or bred in a hatchery [32, 40].

Large structures are costly to manufacture and transport, involving the deployment of large vessels, and do not guarantee that flat oysters will settle [38-40]. A reef ball costs around €1000,- per piece, an iron cage with oysters is around €4000,- per piece, and 1 m³ of empty oyster shells cost between twenty and hundred euros [42].

The second point of attention is that large structures of foreign material need to be removed from the sea bed, as stated in this report's part about regulations in the Dutch North Sea. This means that all placed structures, including on-grown reef or not, need to be removed and there is no final impact.

Another point of the discussion revolves around the placement of large structures like cages or 3D towers. The bed of the Dutch North Sea exists (and has existed) for the majority out of sand [36]. Naturally, no large hard substrate is present, except in the Dutch southern parts close to the province of Zeeland. Therefore, from an ecological perspective, it seems undesirable to place large hard substrates that do not naturally occur [6].



Figure 23: *Ostrea edulis* on the sea bed (photo: NORA).

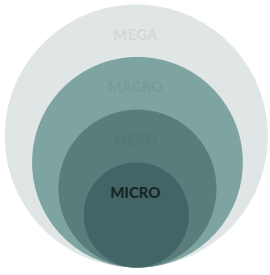

What are the preferences for flat oyster larvae settlement?

How does settlement work naturally?

It is useful to know how settlement naturally works, so this could be mimicked in the settlement procedure of the 'reef tiles'.

Ostrea edulis start their lives as larvae, after which they metamorphose into shelled oysters [21]. Gregarious settlement in oysters is induced by settlement cues that enable pelagic larvae to recognize reef habitat and conspecifics by sight, sound, or smell [22].

Flat oysters need some hard substrate for initial settlement but can then build an existing reef

over soft substrate [9]. It is known that in natural conditions, most larvae prefer to settle on living oysters or shells from recently dead conspecifics (e.g. [43-45]), but they also settle on other hard substrates like rock, gravel, or sand [44]. Oyster larvae settle permanently by cementing themselves to the substrate [21].

Main takeaways to base the design criteria on:

- The material should be hard to allow for larvae settlement.



Figure 24: Newly settled spat on shell (photo: VIMS).

What is the preferred alternative substrate?

If there is a specific material that attracts oyster larvae, this could be incorporated in the design, increasing the settlement potential of the 'reef tiles'.

Fourteen types of material were investigated. Mainly, calcareous materials (like limestone) are preferred (e.g. [46]). Materials with potential negative effects on the environment should be avoided, for example, porcelain or concrete.

Below is an overview of the examined materials. For a complete overview of researched materials, see Appendix 3.

Main takeaways to base the design criteria on:

- The material should be calcareous, to promote larvae settlement;
- The material should be biologically safe (no chemical pollution).

Calcareous material:



Non-calcareous material:

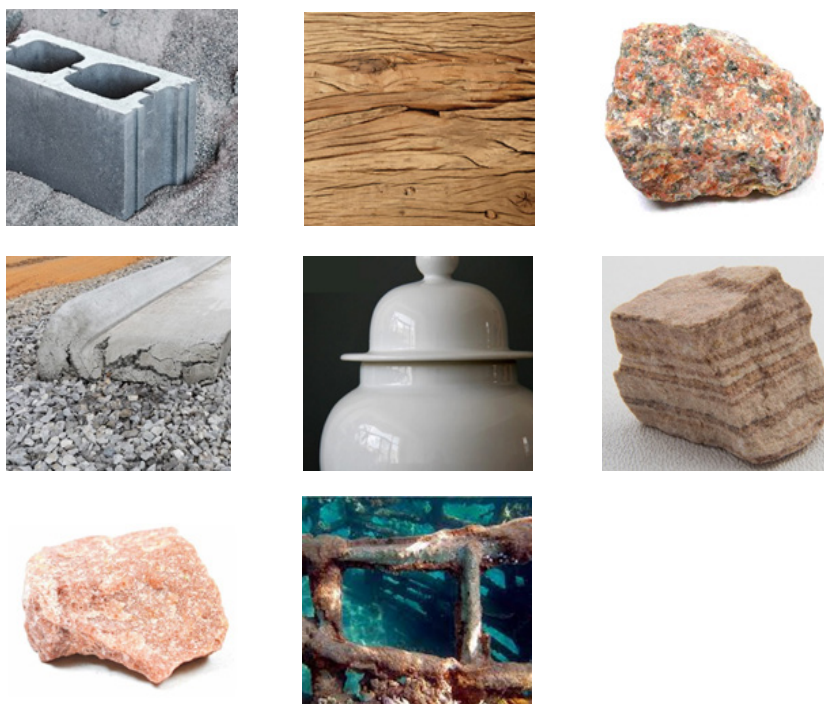

Figure 25: Overview of researched materials.

What type of surface do flat oyster larvae prefer?

If there is a specific type of surface that attracts oyster larvae, this could be incorporated in the design, increasing the settlement potential of the 'reef tiles'.

Surface characteristics, i.e., topography at a microscale, can play an important role in the larval settlement [47, 48]. Potet et al. (2021) suggest that microscale surface texture has a greater impact on recruitment than material formulation [49].

Smooth surfaces, such as very smooth pebbles, glass or seaweed, are intrinsically unsuitable for *O. edulis* recruitment [43]. The ideal surface texture must have irregularities and slight concavities at a microscale [49]. Grooves and sub-cryptic surfaces provide refuges.

Potet et al. (2021) found that larvae preferred to settle in depressions on rough rock-like textures and that they avoid flat, horizontal, and exposed areas [49]. Grooves provide spatial refuges from incidental grazing of settled spat and are advised to be considered in settlement substrate designs to enhance settler survival [47, 50]. A biofilm increases larval settlement [51-53]. Non-porous surfaces prevent algae formation [50].



Figure 26: Biofilm on a concrete unit (photo: SECORE).

In-depth

Difference between algae and biofilm: biofilm consists of bacteria and fungi, while algae are photosynthetic organisms.



Figure 27: The surface of a native oyster shell (photo: ZSL).

Main takeaways to base the design criteria on:

- The product's surface should provide spatial refuges;
- The product's surface should allow for biofilm formation.

What are other useful conditions/characteristics for larvae settlement?

If there are specific characteristics that attract oyster larvae, this could be incorporated in the design, increasing the settlement potential of the 'reef tiles'.

Larvae have a preference for dark-coloured substrates; when larvae settle, suggested is that they avoid light exposition by fixing on more shadowed and protected areas [54-56]. Potet et al. (2021) advise orientating substrates so that larvae can settle vertically, as larval fixation is enhanced when substrates are vertical [49, 57]. Substrates should be in a stable position [42].

<1.5m to nearest conspecific neighbours results in greater production of brooded larvae [60].

In cultivation, six to eighteen months after settlement, the grown spat is detached from their substrate and laid out to grow. This indicates that a substrate is not crucial anymore at this stage [61].

With elevation on a reef the flow speed increases and sedimentation decreases, which is favourable [28, 58, 59]. A maximum distance of

Main takeaways to base the design criteria on:

- The product should provide shadowed or protected areas;
- The product should provide options for the larvae to settle vertically;
- The product should be stable in as high flow velocities as possible;
- The product should exist on the seabed for minimally six months.



MAIN DRIVERS

Based on the research presented in the previous chapter, requirements for the design were formulated. A full list of product requirements and wishes can be found in Appendix 4. This chapter is part of the 'Define' phase.

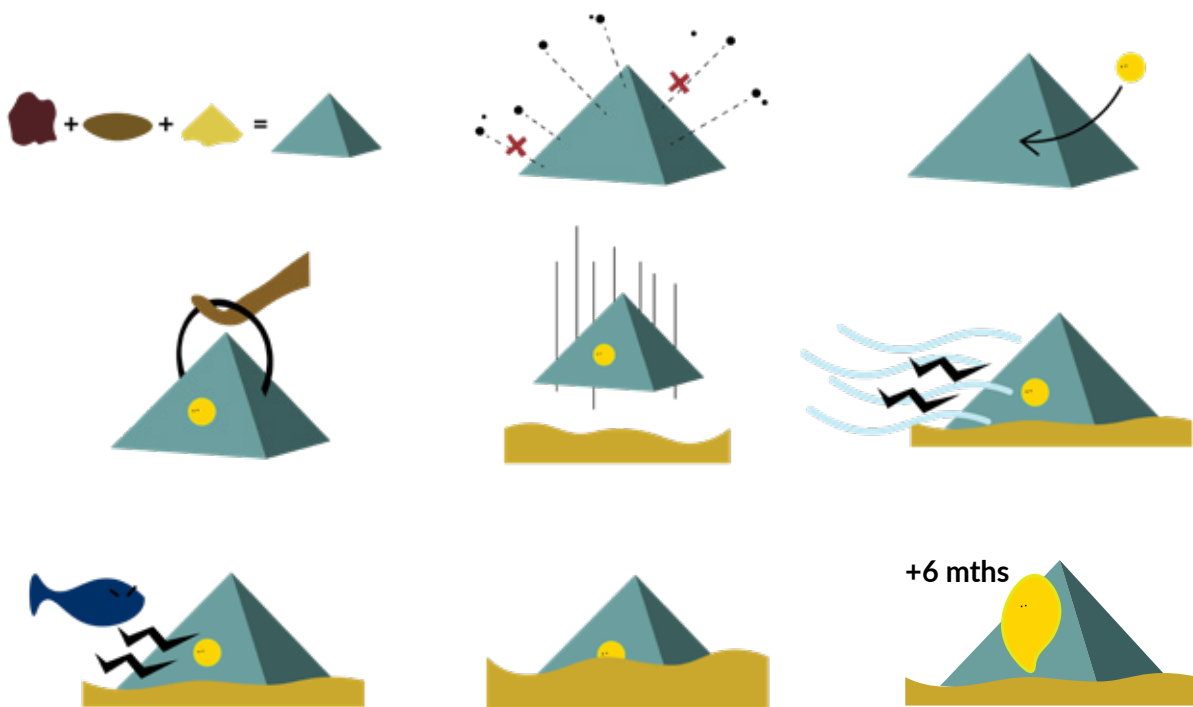

The following requirements are most important in the design process of both the material as the form:

Material:

1. The material should be naturally occurring in the Dutch North Sea;
2. The material should be biologically safe (no chemical pollution);
3. The material should be hard to allow for larvae settlement;
4. The material should be denser than seawater ($>1023.6 \text{ kg/m}^3$), for the product to sink;

Form:

5. The product should allow people to touch/hold it without touching settled spat;
6. The product should be stable in flow velocities up to 0.8 m/s ;
7. The product should enable oysters to have access to flowing water, as this is how they feed;
 - 7.1 The product should make sure the larvae stay above the sediment (sand of $<0,5 \text{ mm}$), so less than 50% burial;
8. The product should protect larvae against larger predators;
 - 8.1 The product's surface should provide spatial refuges;
9. The product should be large enough for a grown oyster of five centimeters long;
10. The product should exist on the seabed for minimally six months.

To read the argumentation of the choice for naturally occurring material over degradable material, see Appendix 5.



IDEATION

To fulfil the requirements stated in the previous chapter, bio-based materials were explored and a final material was chosen. Basic shape sinking and landing behaviour were the starting point of the idea generation. The best ideas were executed as clay models, of which the most promising were 3D-printed. These 3D models were iterated until five concepts met the design requirements.

The ideation, also called the 'Develop' phase, concentrated on developing and trying out multiple potential solutions, also called conceptualization. This phase was twofold: a material had to be chosen (this material impacts the possibilities and restrictions for the form) and a form.

A practical approach enabled quick iterations, meaning that the process was repeated until satisfied with the design. The goal of this phase was to present between three and five concepts that could be tested: at least two concepts derived from conceptualization, and one being the existing embodiment of the 'reef tile'.

MATERIAL EXPLORATION

The main requirement for the material was that it should be naturally occurring in the Dutch North Sea (and therefore also be bio-based). In the sea, there are two groups of insoluble materials to take inspiration from: sand particles, and marine organisms.

Based on mineral and chemical composition, three types of sand can be distinguished: Silicate sands (quartz and feldspar), Carbonate sands (calcite and aragonite, originating from shell and coral fragments), and Gypsum sands (crystal forms of gypsum, moderately soluble in water) [62]. Marine organisms that are inspiring to look at are algae and seaweed.

Different types of these materials have been explored. Existing material recipes have been tried, consisting of mainly six ingredients in several different compositions. The ingredients were: gypsum plaster (a calcium-based casting material that is easily available), calcium carbonate (the main component of seashells), alginate (comes from a species of brown algae), agar-agar (comes mainly from red algae). See Appendix 6 for the full exploration.



Figure 28: Examples of bio-based materials that could be suited.

The material that performed best in the exploration was gypsum plaster, chemically called calcium sulfate dihydrate ($\text{CaSO}_4 \bullet 2\text{H}_2\text{O}$). This material is a common constituent of sedimentary marine rocks. It is slightly soluble in water and is therefore expected to dissolve over time. In terms of producibility, this material can be cast and does not shrink during the drying and hardening process, making it a suited applicant for this product. With a density of around 1900 kg/m^3 , the material's density is larger than seawater ($>1023.6 \text{ kg/m}^3$), meaning that the product sinks.

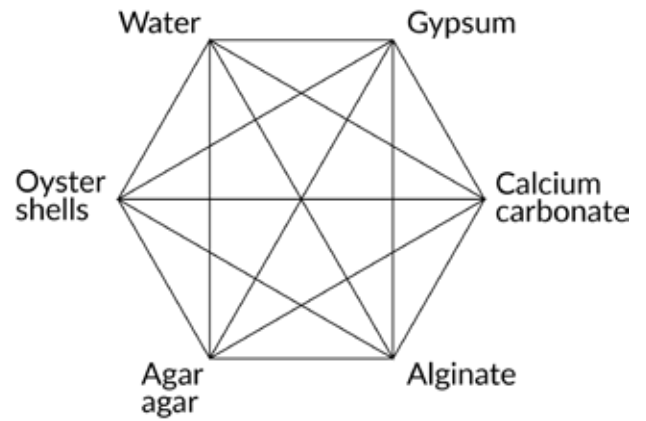

Figure 29: Six suitable ingredients that can be mixed.



Figure 30: A few of the tested material recipes.

SHAPE EXPLORATION

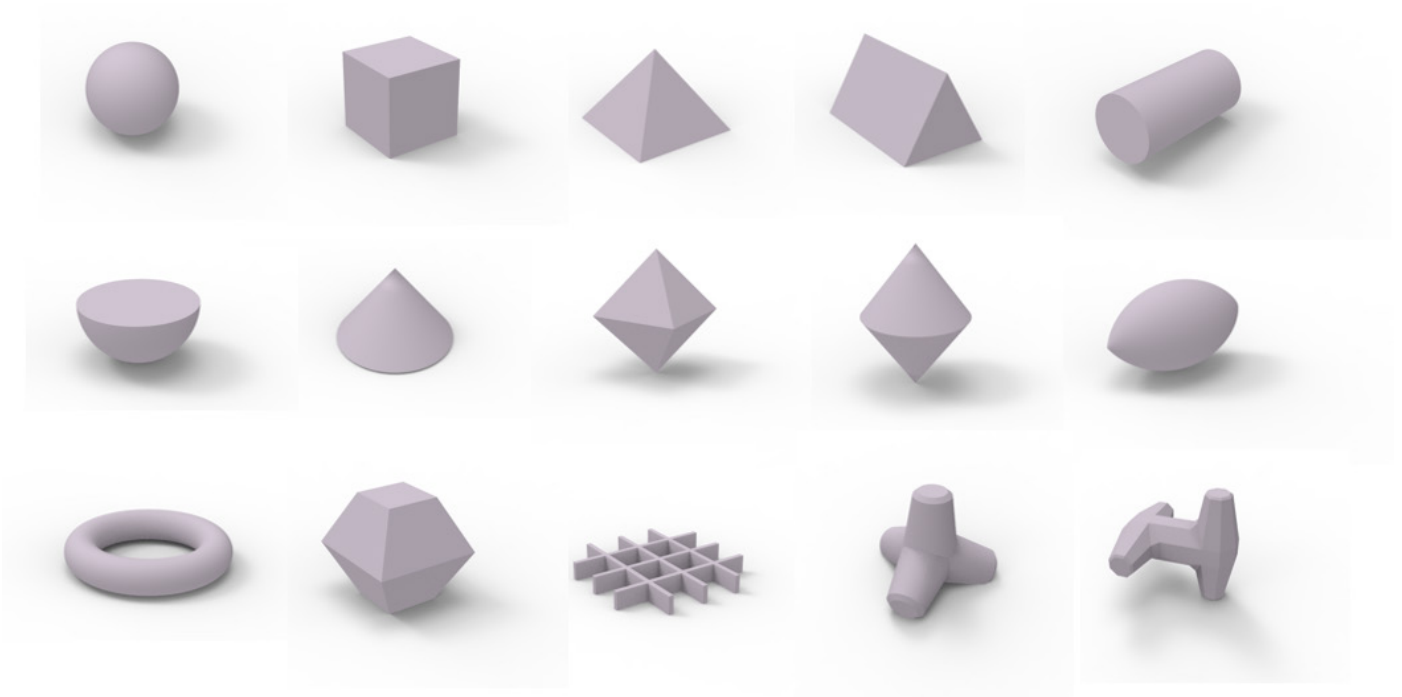

Figure 31: Overview of the tested shapes.

Basic shape exploration

Several basic shapes have been tested on sinking and landing behaviour in shallow water. The goal of this test was to find out how the shapes tend to land (determined sides) and how they tend to stabilize during the sinking phase. Because reference models were absent, basic shapes were chosen to test, as a starting point for the idea generation. This enabled a systematic approach.

The shapes were 3D-printed with PLA with 80% infill, so the objects would sink. The test was executed in 80 cm deep water. As expected, the irregular shapes mostly landed on the sides where the centre of gravity was closest.

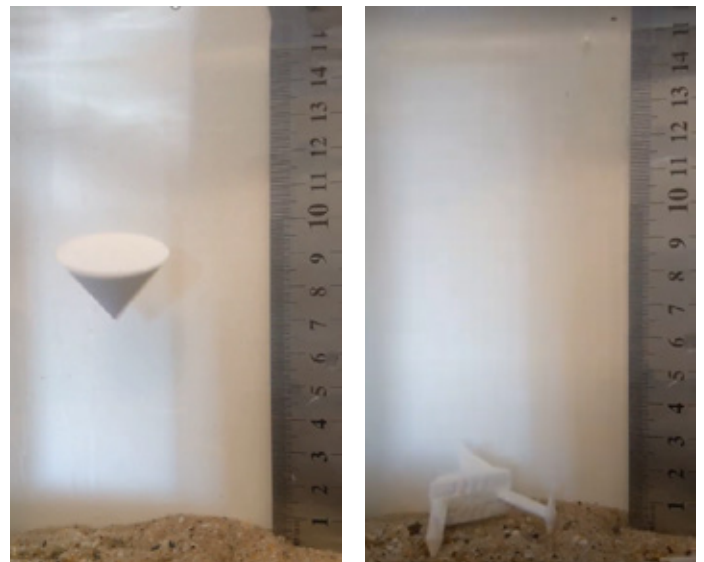

Figure 32: Two shapes during the sink test.

Idea generation

The basic shapes were used as starting point for the idea generation. None of the basic shapes were suited for the application. So, how could they be altered in such a way that they would? The main focus during this process was

on defining a shape, based on the basic shape, that has one surface that could never touch the sea bed.

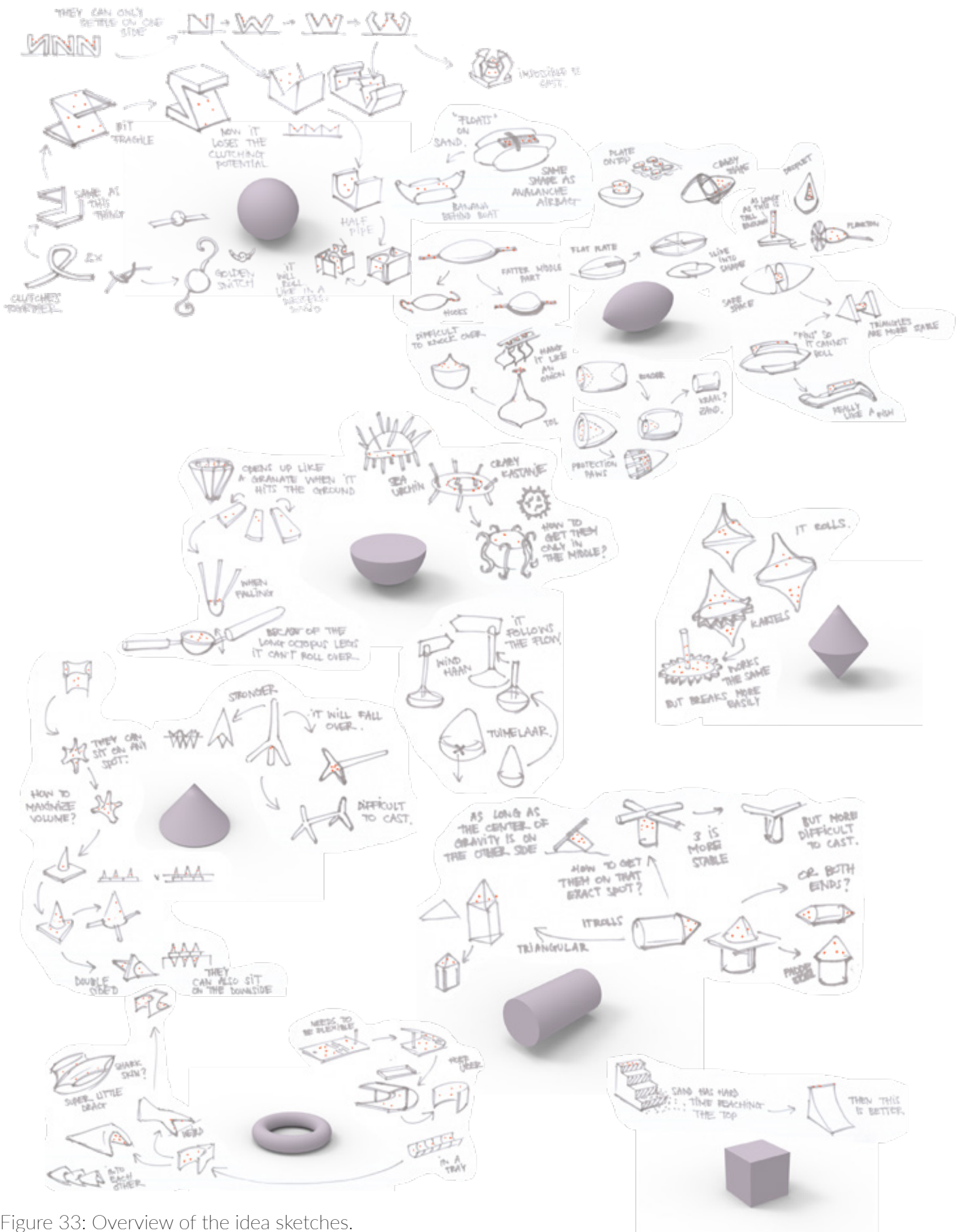

Figure 33: Overview of the idea sketches.

Physical exploration

The best ideas from the previous step were chosen, based on logical reasoning and personal evaluation, to embody as clay models.

A preliminary evaluation of function works better in 3D than in 2D, in my opinion.

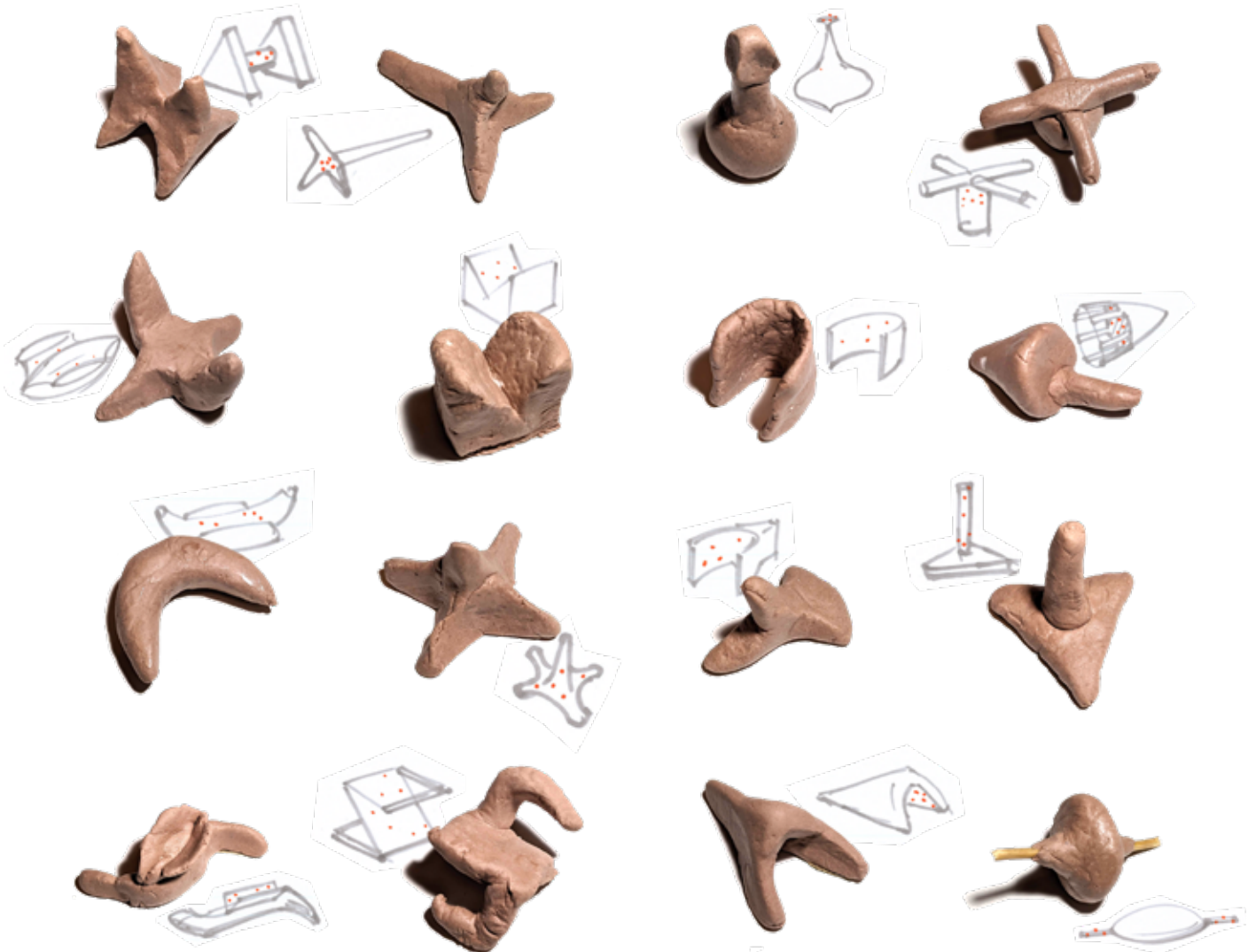
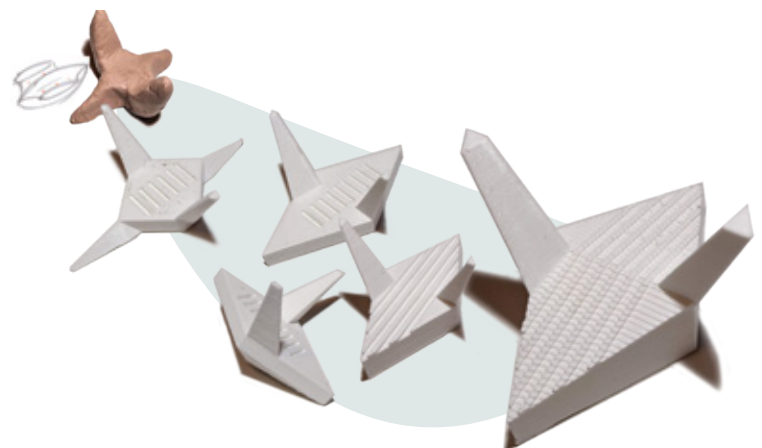

Figure 34: Overview of the clay models.

Concept generation

The four best performing clay models were worked out as 3D-printed models, based on personal estimation of potential. 3D models are more accurate than clay models and are therefore more reliable to evaluate. These preliminary concepts were then iterated further (some even ten times) until the concept felt like it met the requirements best.



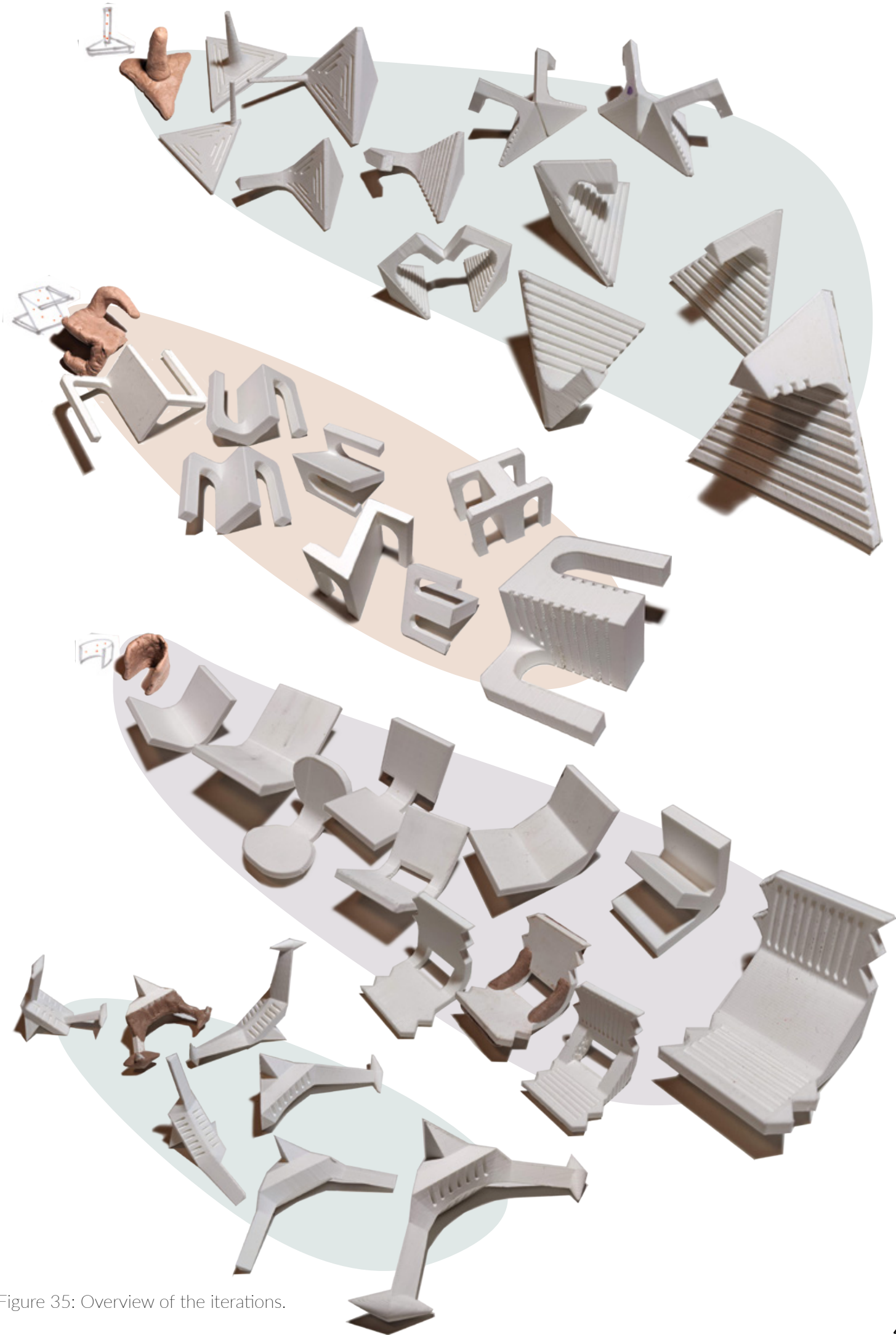

Figure 35: Overview of the iterations.



CONCEPTS

The ideation process as described in the previous chapter led to five concepts for the reef tile. This chapter describes the concepts in detail.

The five concepts were worked out to a level where they best met all requirements applying to the shape; all other requirements were omni-applicable. Out of these concepts, four were generated by me, one was optimized from the existing prototype.

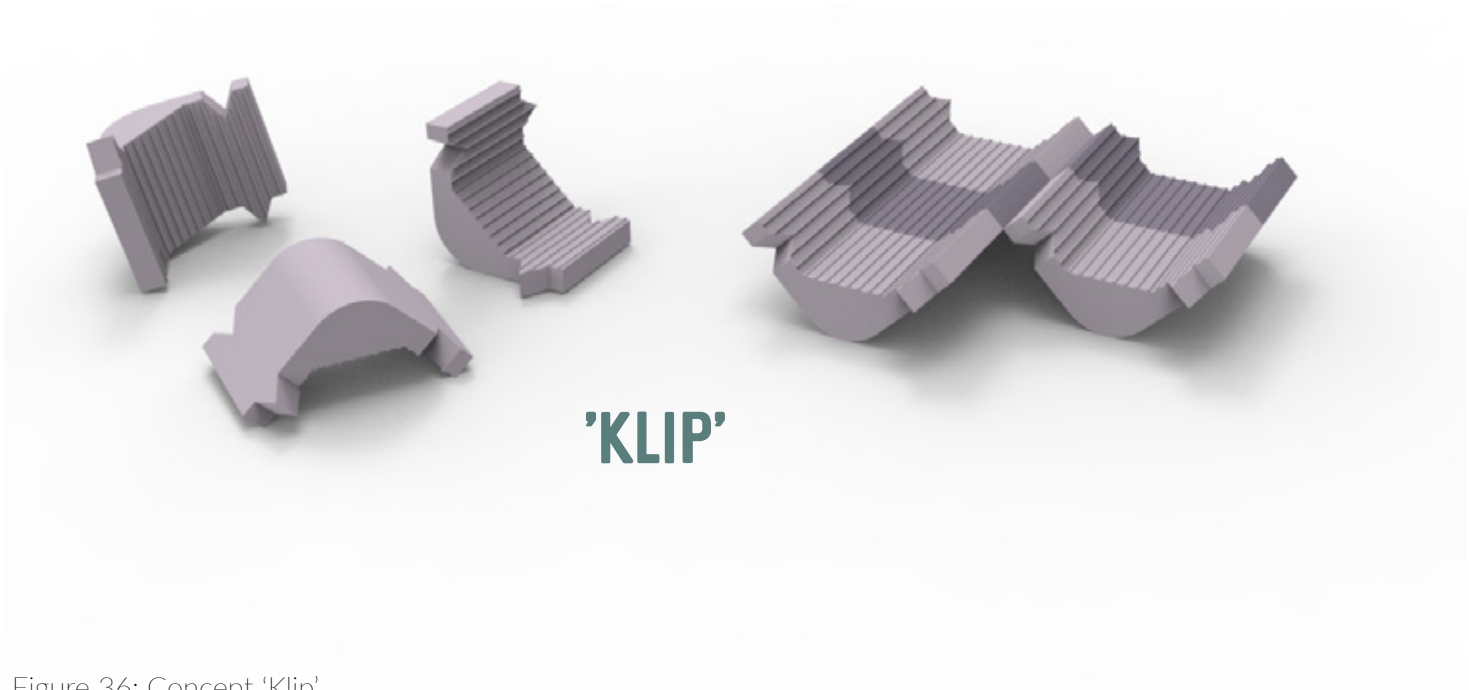
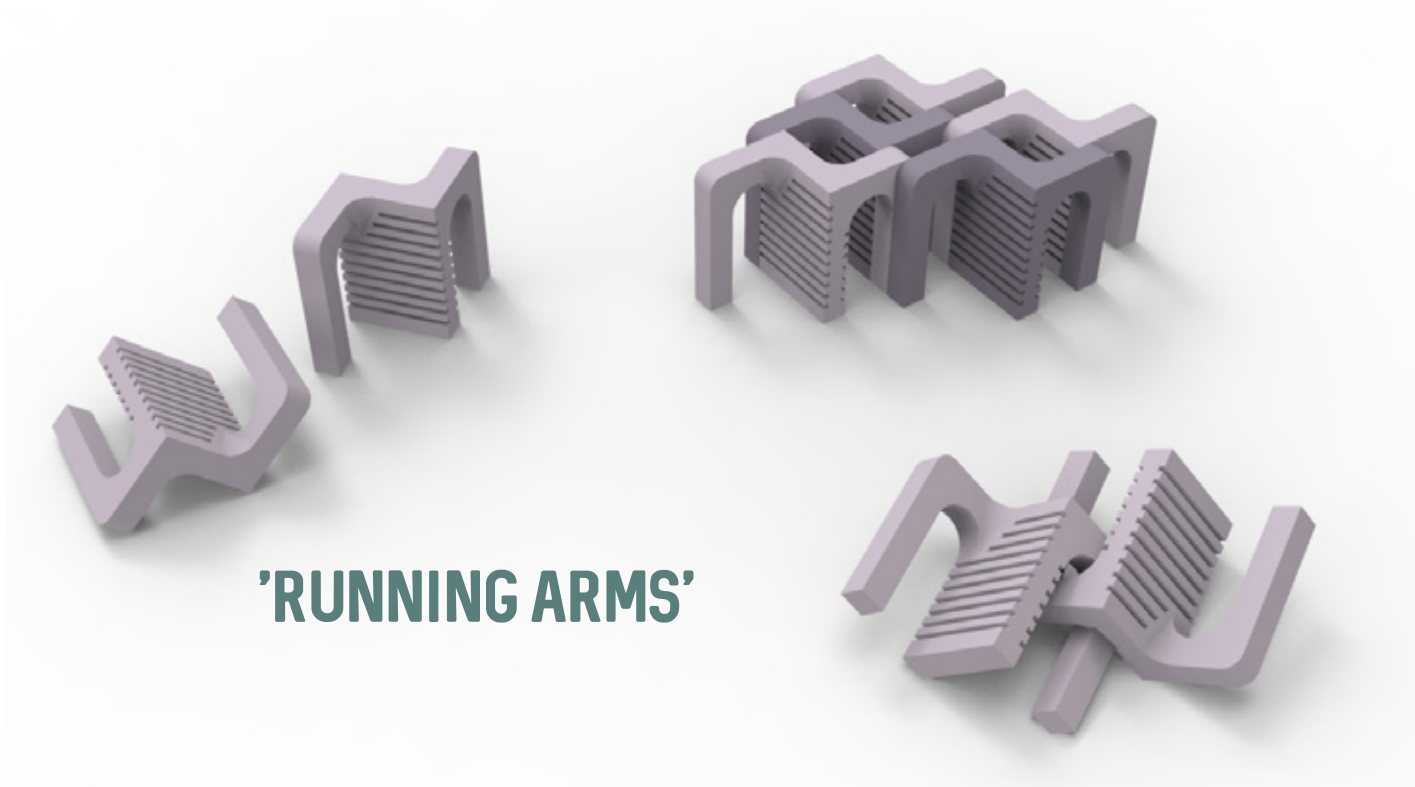

Figure 36: Concept 'Klip'.

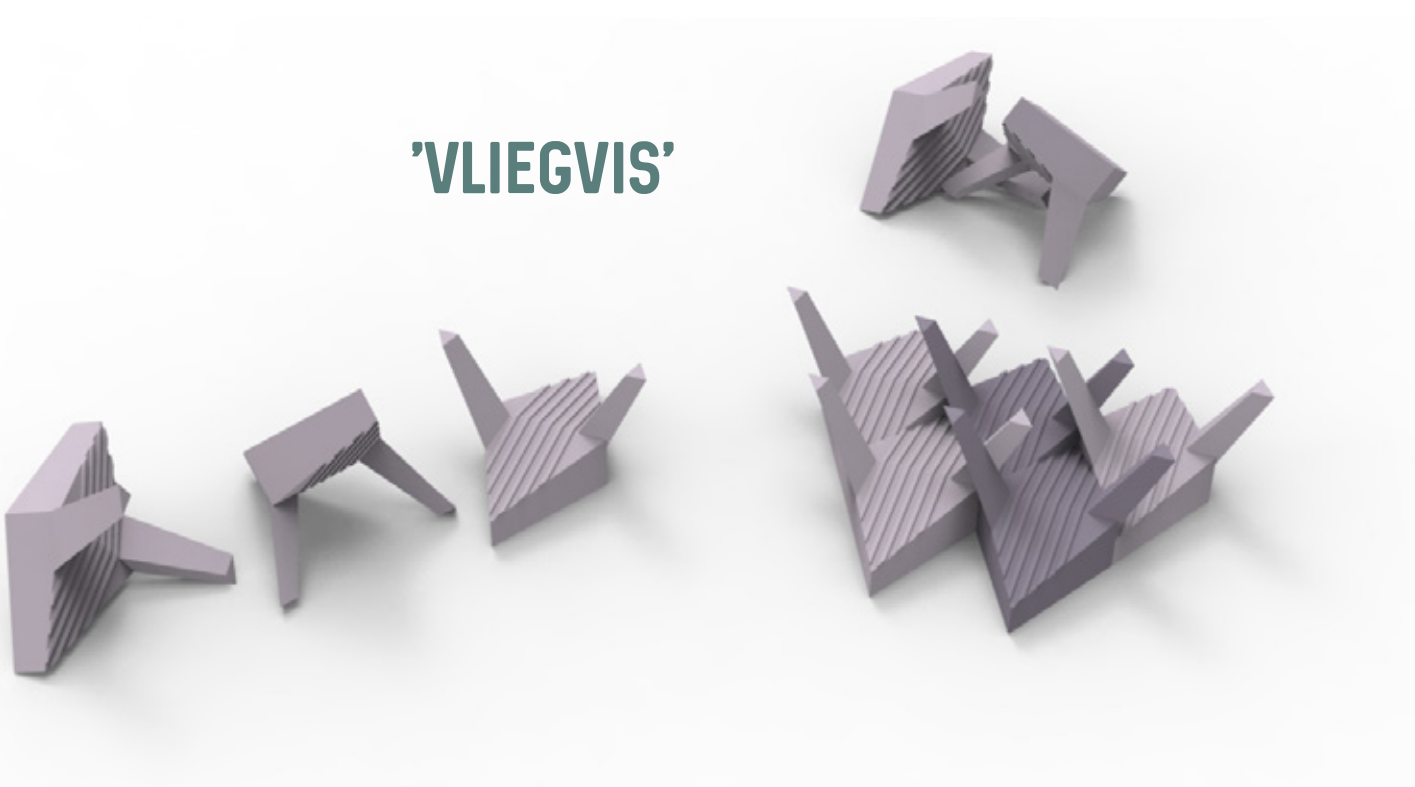

Figure 37: Concept 'Driehoekpaal'.



'RUNNING ARMS'

Figure 38: Concept 'Running arms'.



'VLIEGVIS'

Figure 39: Concept 'Vliegvis'.

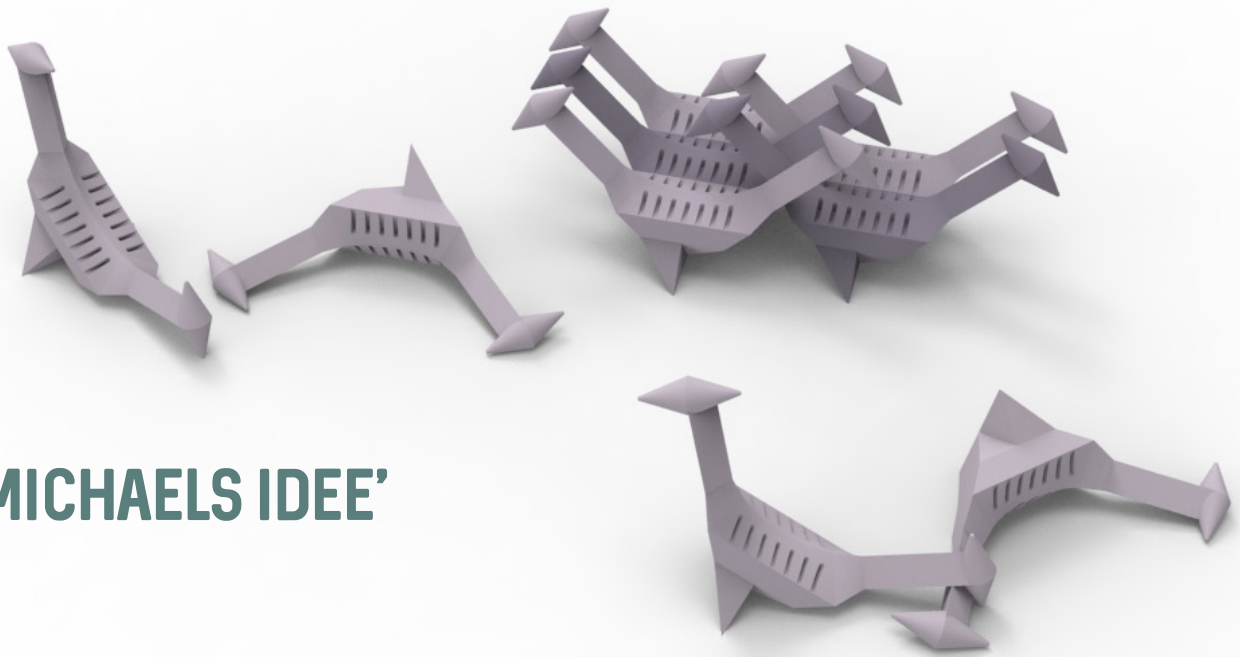

'MICHAELS IDEE'

Figure 40: Concept 'Michaëls idee'.



CONCEPT CHOICE

The evaluation of the concepts was based on the weighted objectives method, which resulted in a ranking. The concepts “driehoekpaal” and “Michaël’s idee” were chosen to use for the functionality tests.

The five concepts were ranked based on the objectives applying to the shape; requirements regarding material or surface were omniscient. The objectives were given a weight

based on importance. A score between 0-10 was given based on how well the concept met the requirement; these grades were all fact-driven.

Stability: The strength to endure most water flow on the seabed without movement. Representing a defined and stable base, clutching potential, or a high mass.



Floating on sand: The least amount of burial by sand of the spat-bed. Representing the height of the spat-bed above the seabed; least possibilities for the spat-bed to land facing down.



Handling: The highest number of products per tray of 400x300 mm with a maximum of 13 kg (mean weight that women can carry at elbow height) [63].



Lifetime: The longest amount of time until dissolution, related to the lowest surface-volume ratio, assuming volume is similar for all concepts (10 - ratio number).



Conservation of spat: The highest amount of dedicated surface for spat (spat-bed) compared to non-dedicated surface in the transport tray.



'DRIEHOEKPAAL'

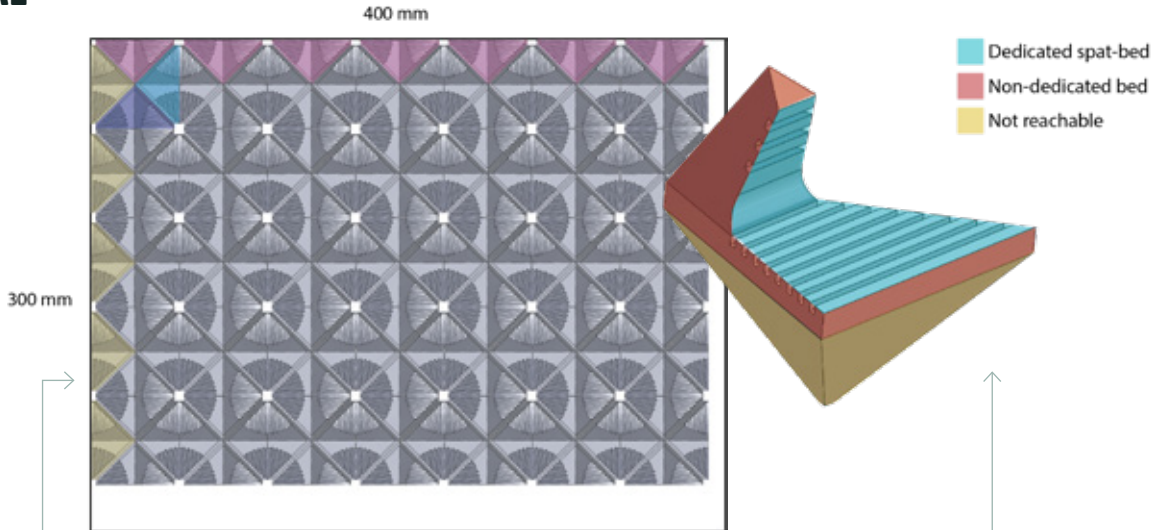
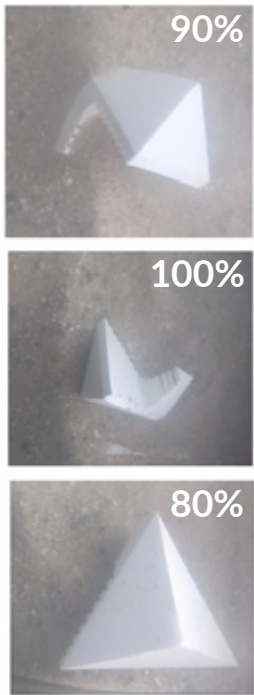

Stability (percentage time idle): 100%
Floating on sand (percentage sand): 90%
Handling (amount per standard tray): 140 products
Lifetime (surface-volume ratio): 3,2 : 1
Conservation of spat (dedicated to non-dedicated bed ratio): 65%

'KLIP'

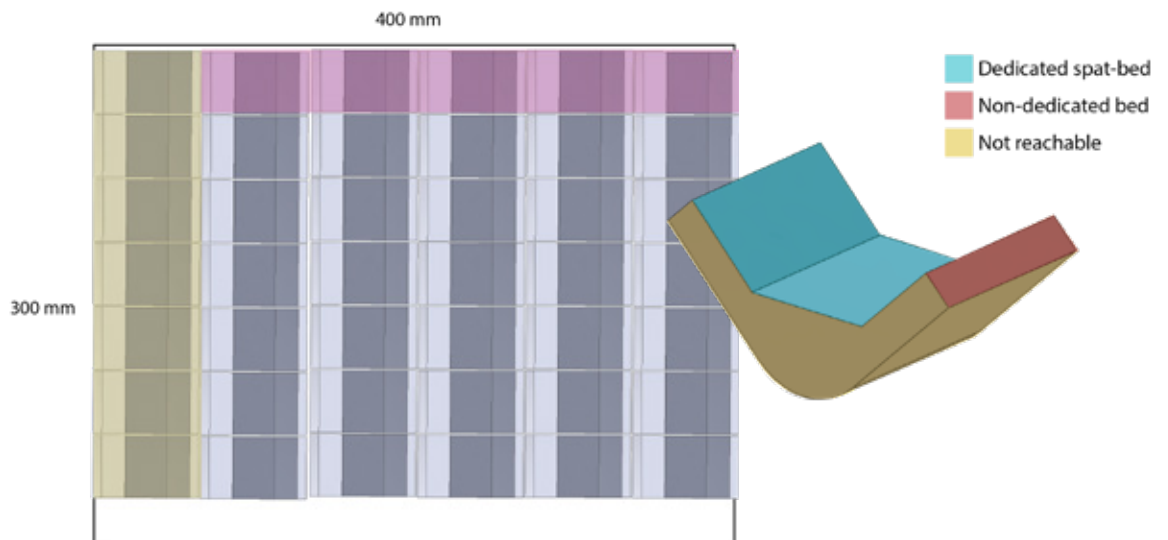

Stability (percentage time idle): 60%
Floating on sand (percentage sand): 67%
Handling (amount per standard tray): 42 products
Lifetime (surface-volume ratio): 2,6 : 1
Conservation of spat (dedicated to non-dedicated bed ratio): 83%

'VLIEGVIS'

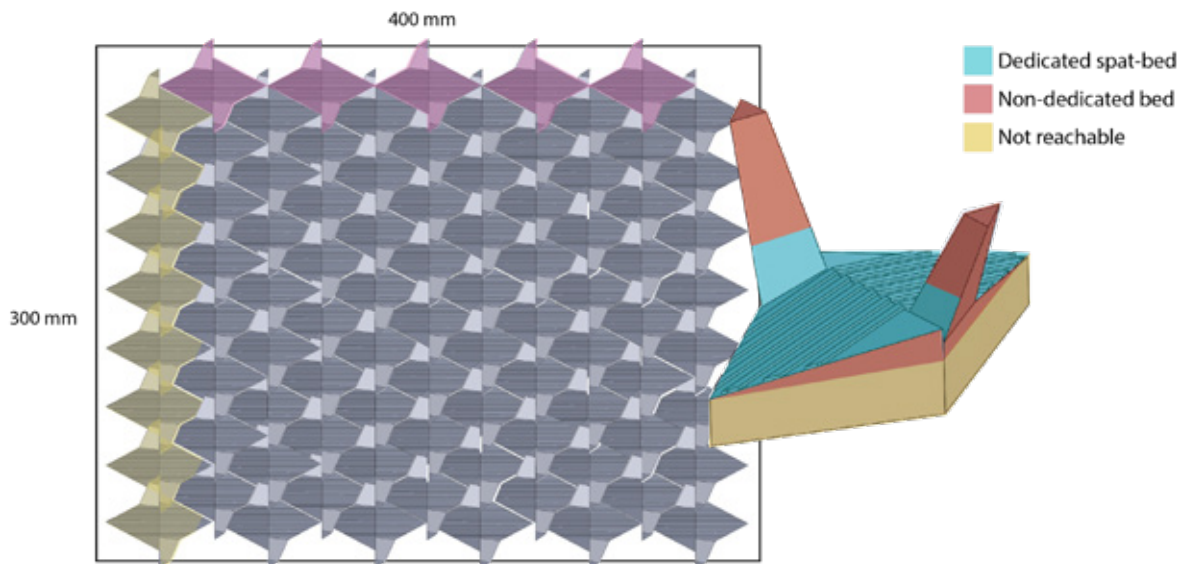

Stability (percentage time idle): 80%

Floating on sand (percentage sand): 32%

Handling (amount per standard tray): 88 products

Lifetime (surface-volume ratio): 3,6 : 1

Conservation of spat (dedicated to non-dedicated bed ratio): 68%

'RUNNING ARMS'

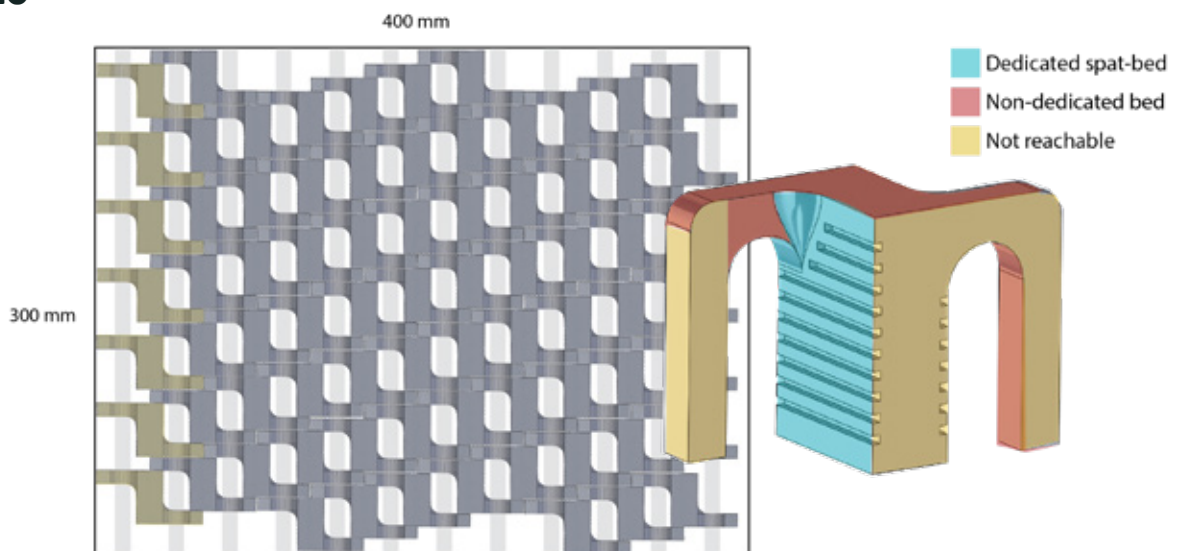

Stability (percentage time idle): 100%

Floating on sand (percentage sand): 90%

Handling (amount per standard tray): 75 products

Lifetime (surface-volume ratio): 3,4 : 1

Conservation of spat (dedicated to non-dedicated bed ratio): 71%

'MICHAELS IDEE'

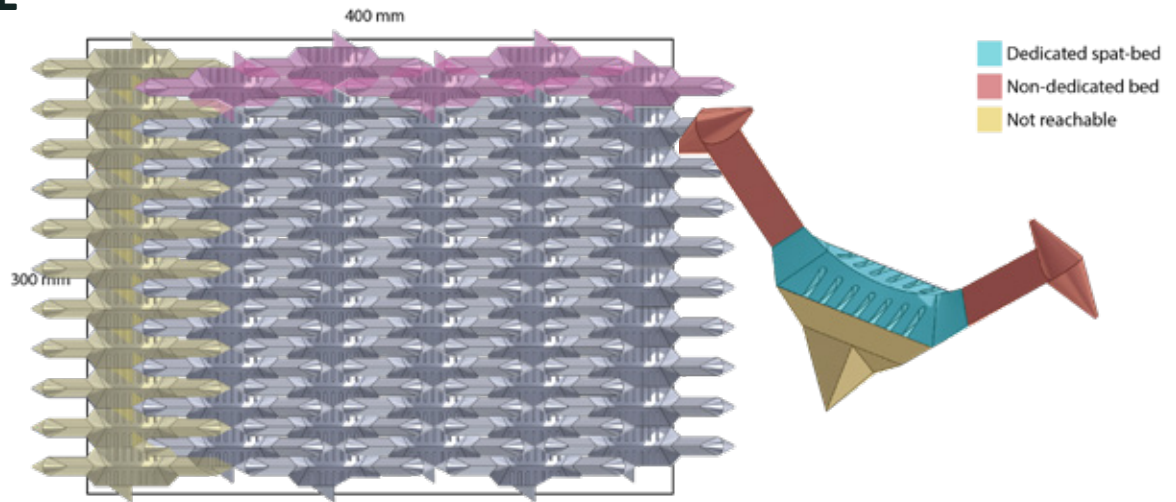

Stability (percentage time idle): 100%
Floating on sand (percentage sand): 93%
Handling (amount per standard tray): 63 products
Lifetime (surface-volume ratio): 3,5 : 1
Conservation of spat (dedicated to non-dedicated bed ratio): 40%

The weighted-objectives showed that the concept 'Driehoekpaal' scored best. Mainly, the compact handling is a large difference with the other concepts.

As it had been decided already that the concept 'Michaëls idee' would be tested in the flume experiment, 'Driehoekpaal' and 'Michaëls idee' will be prototyped, which can be seen in the next chapter.

		Concept 1		Concept 2		Concept 3		Concept 4		Concept 5	
	Weight	Score	Total	Score	Total	Score	Total	Score	Total	Score	Total
Stability	30	8	240	10	300	10	300	6	180	10	300
Floating on sand	30	3	90	9	270	9	270	7	210	9	270
Handling	15	6	90	5	75	9	135	3	45	4	60
Lifetime	15	6.5	97.5	6.5	97.5	7	105	7.5	112.5	6.5	97.5
Conservation spat	10	7	70	7	70	6.5	65	8.5	85	4	40
	100		587,5		812,5		875		632,5		767,5

FUNCTIONAL PROTOTYPING

The two concepts were made as if real: cast in gypsum plaster. This chapter explains the casting process and shows the two functional prototypes.



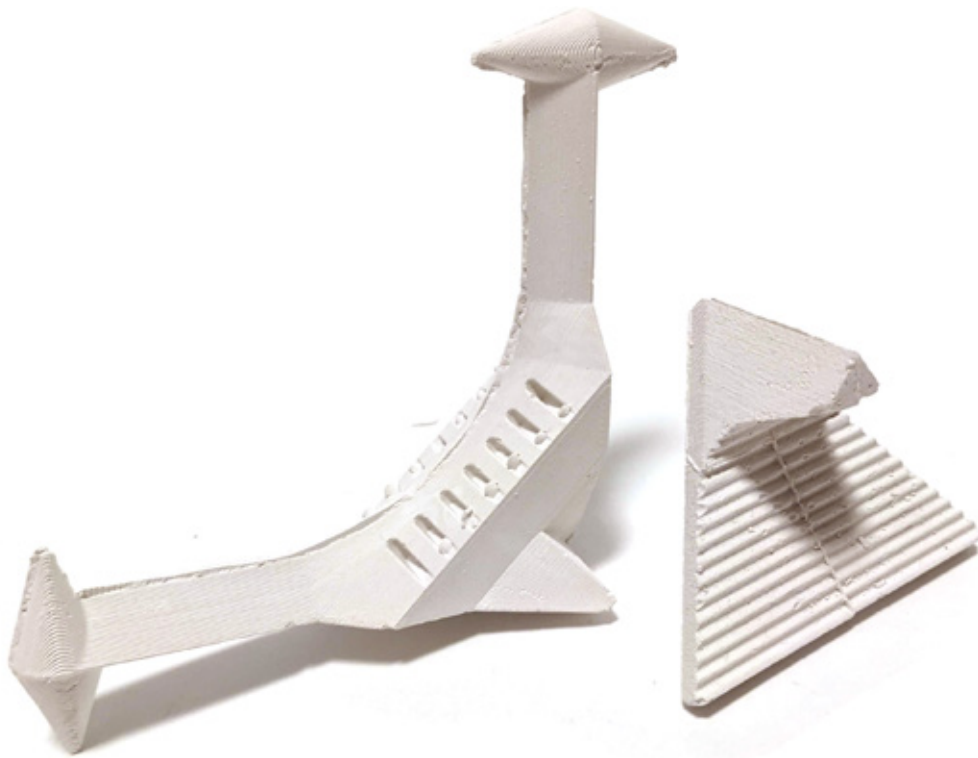
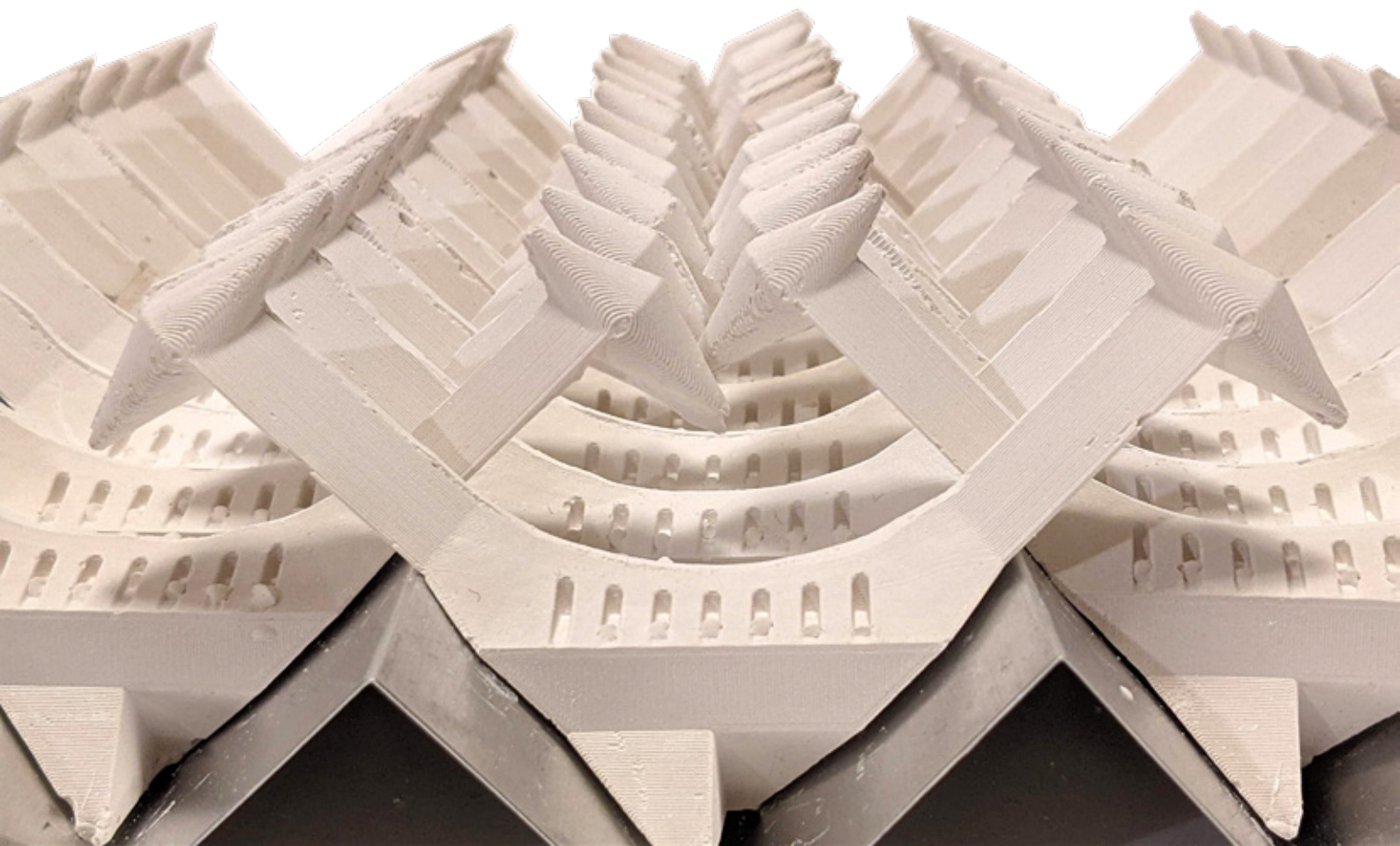

Figure 41: Prototypes of the two concepts.

The concepts were prototyped by casting gypsum plaster in 3D printed molds. The molds were designed by cutting out the volume of the concept from a solid block and iterating until demolding went properly.

“Michaël’s idee” is more detailed and therefore also more difficult to cast. This concept needed to be cast in a silicone mold; printed PLA did not demold. The “Driehoekpaal” could be cast easily in 3D printed polylactide (PLA), however, Vaseline was used for effortless demolding.



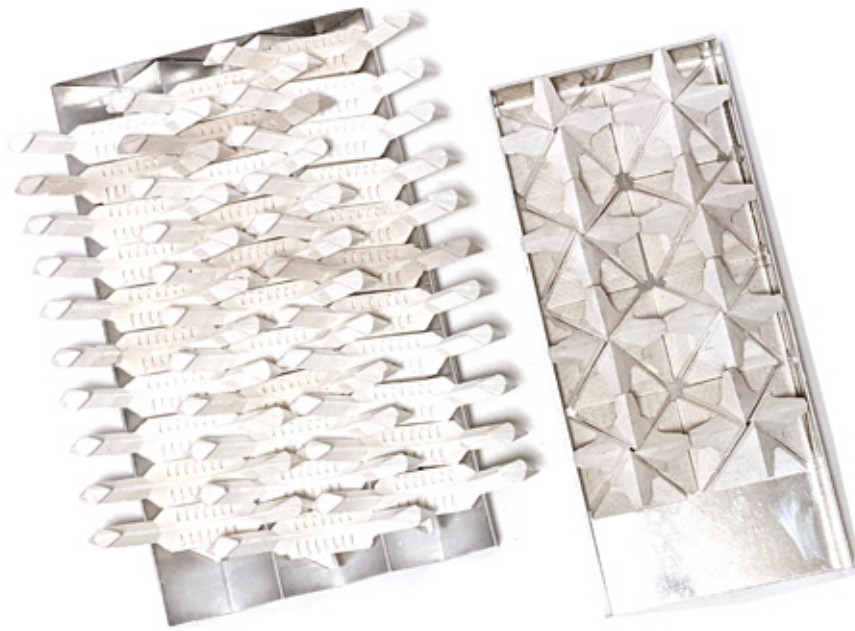

Figure 43: Prototypes in a transporting tray.

The plaster casting cycle followed these steps:

1. With a small brush, evenly apply a thin layer of Vaseline on the inside of the mold;
2. Press the parts together using clamps;
3. Add 250g plaster to 100g tap water (room temperature);
4. Firmly stir the mixture for 2-3 minutes;
5. Cast the mixture into the molds until completely filled;
6. After thirty minutes, open the mold and gently remove the product;
7. Air-dry at room temperature for 24 hours.

Casting plaster needs about five minutes to set, thirty minutes to cure enough to demold, and about 24 hours at room temperature to become completely dry. This means a continuous cycle is difficult to obtain when only having one molds per concept; casting thirty pieces of each concept is a time-consuming process.



Figure 44: Silicone mold part.

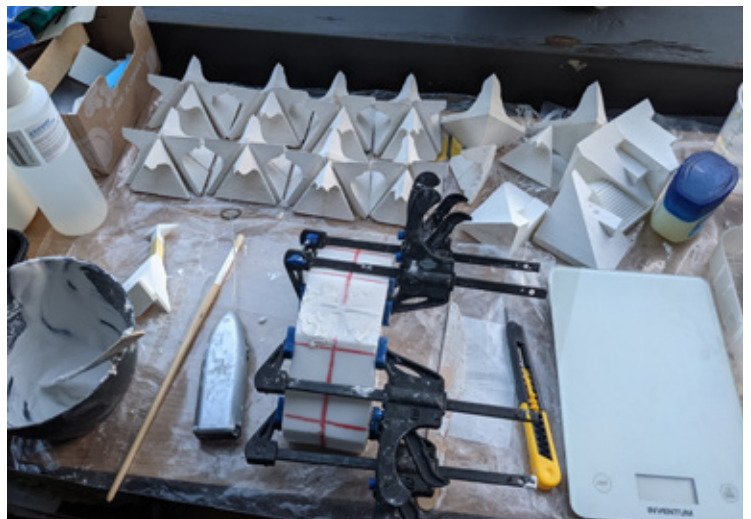

Figure 45: Casting of prototype in silicone mold.

Figure 42 (left): Close-up of prototypes of 'Michaëls idee' in a transporting tray.

In conclusion, prototyping was done manually by casting gypsum plaster in (3D printed) PLA and silicone molds.

Thirty pieces of each concept were made, as those are the required amounts for the flume experiments, to investigate the clutching potential. The flume experiment is described in the next chapter.

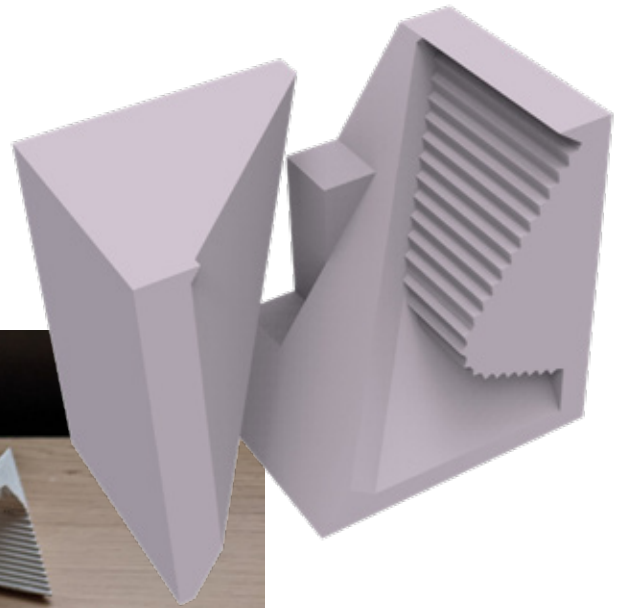

Figure 46: Mold parts.

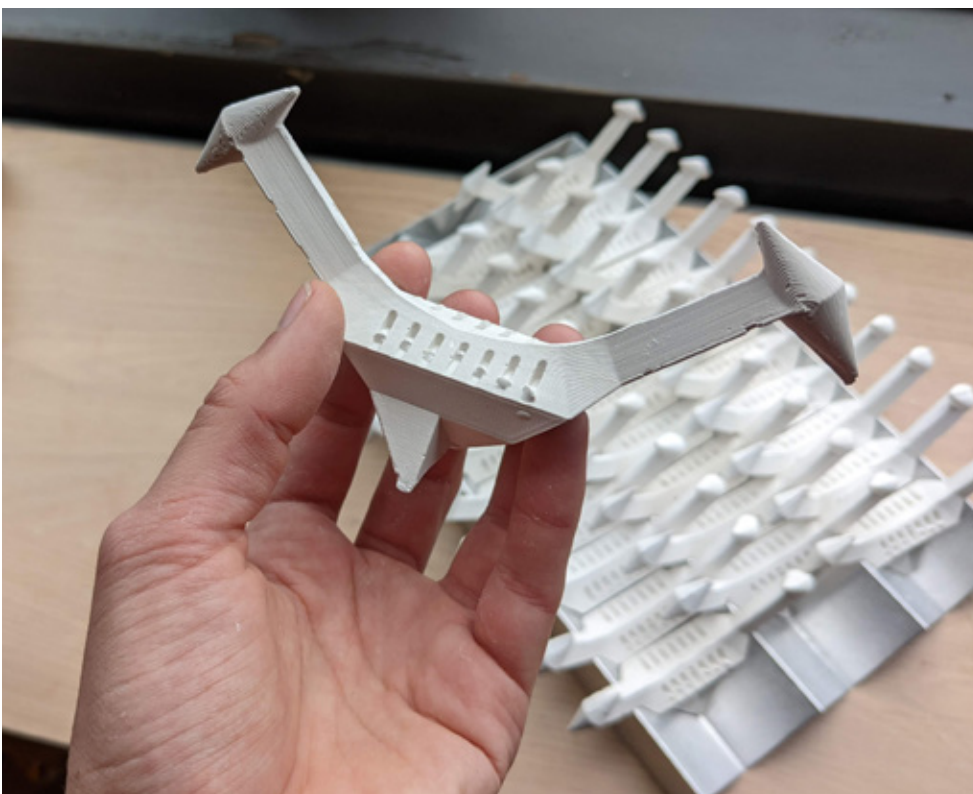
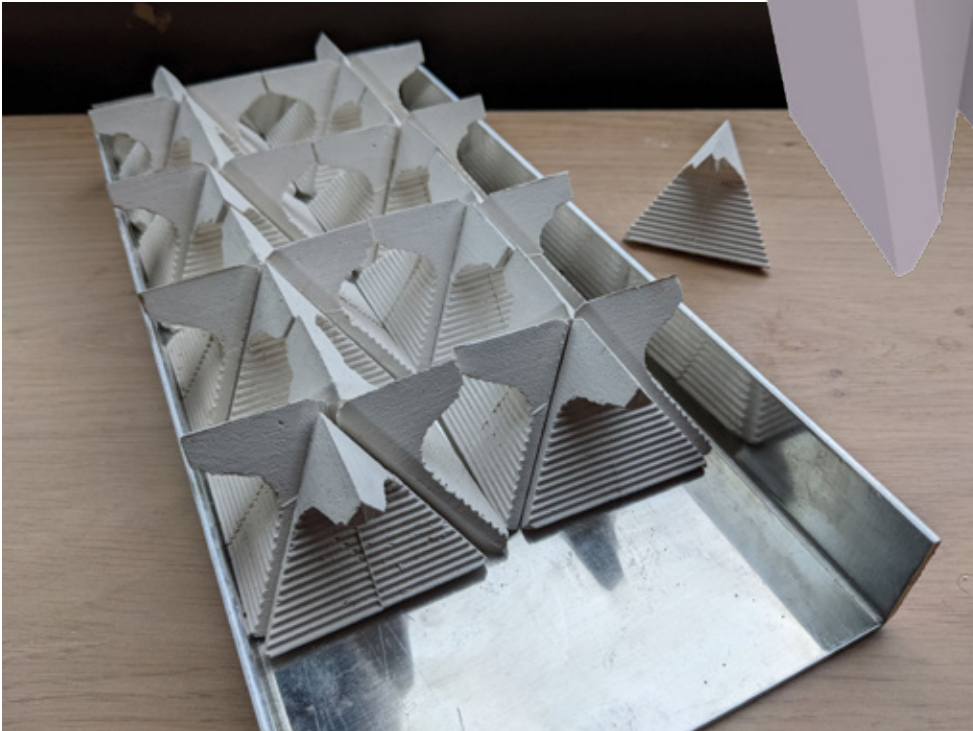

Figure 47 & 48: Close-up of the prototypes in the tray.

FUNCTIONALITY TESTING

Two concepts were tested in a sediment flume to get an indication of performance underwater. One of the two concepts displayed more desirable behaviour in this simulated environment.



To obtain more insight on product stability and burial by sediment, the behaviour of the reef tiles in flowing water was investigated in a series of flume experiments in the Environmental Fluid Mechanics Laboratory of the Delft University of Technology.

The testing objective was to research the behaviour of two oyster reef restoration products on different bed types, in average and annual maximal flow velocity conditions (simulated from reference location Gemini wind park and Borkumse Stenen). The main research question for this experiment was as follows: How well do submerged oyster reef restoration products perform in water flow?

FIELD CONDITIONS:

The reference location for the tests is Gemini wind park (Buitengaats) and Borkumse Stenen. The fact that wind farms are free from seabed-disturbing activities in the current regulatory framework, is regarded as a major precondition for the restoration of flat oyster beds. Next to this precondition, these sites have been chosen as both are at locations where flat oysters used to be distributed, see figure 49. Other locations, for example on the west coast, have no history of flat oyster reefs and here is an occurrence of large sand waves; oysters could not survive in these waves.

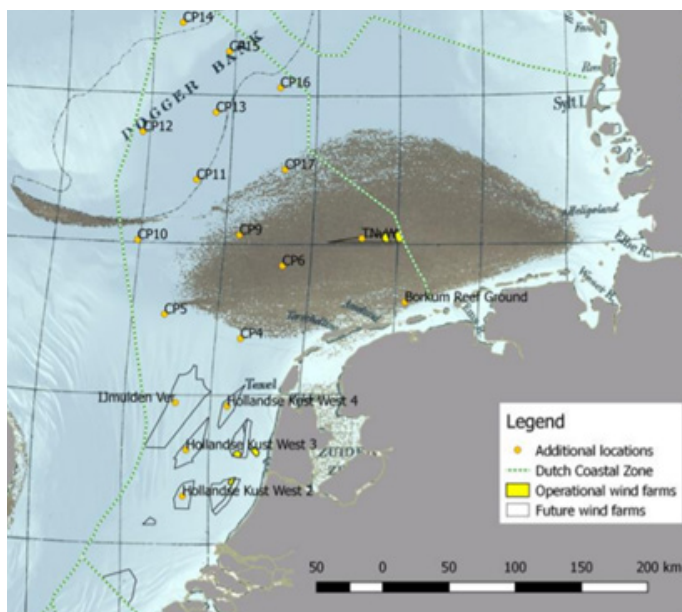

Figure 49: Historical distribution of *Ostrea edulis*.

To answer this main question, sub-questions were formulated to understand the parameters influencing the results.

- Do the products stay above the sediment (have at least 50% of their body above the sediment after twenty minutes)?
- Do the products get in a stable position (fixed within fifteen meters for at least twenty minutes)?
 - Does clustering products (two or more that touch each other) improve their stability (fixed within fifteen meters for at least twenty minutes)?

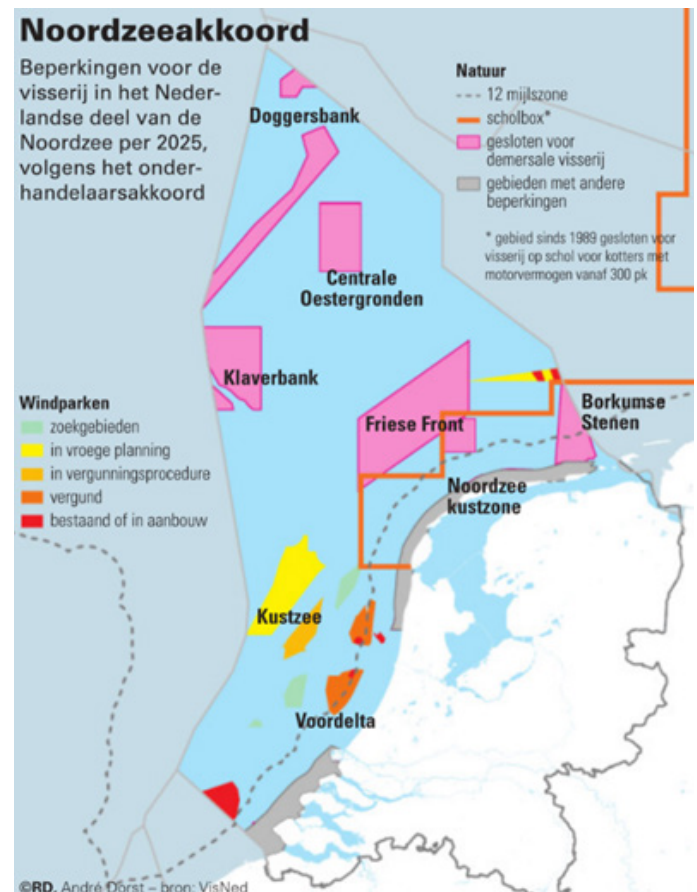

Figure 50: Areas free from bottom fishing (VisNed).

EXPERIMENTAL SETUP:

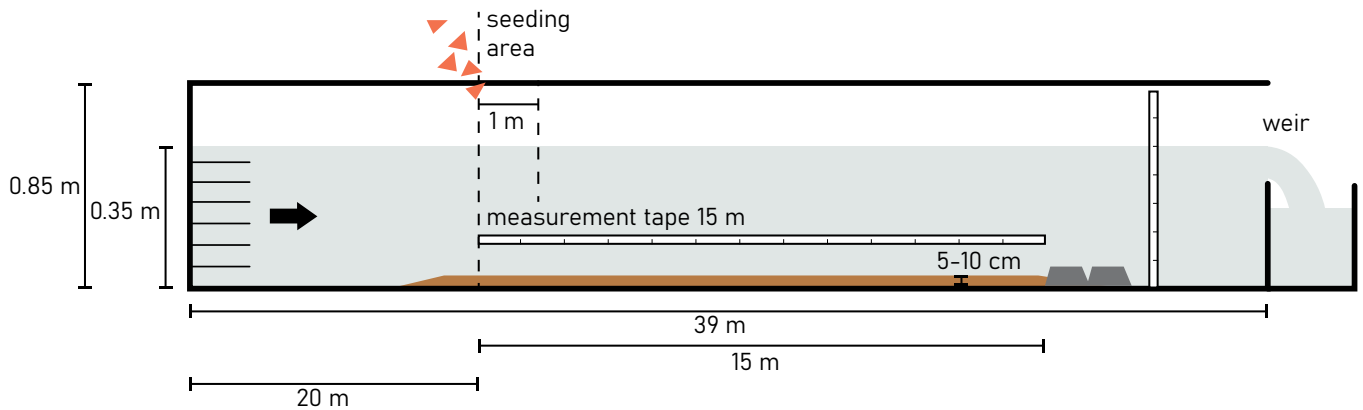

Figure 51: Setup for the flume.

The flume:

The layout of the flume is shown in figure 51. Freshwater is recirculated using a pump. The maximum flow velocity in this flume is 1.0 m/s, which is a steady streaming flow. To achieve this velocity, a water column depth of 35 cm is required.

The dimensions of the flume are: effective length: 39.0 m, width: 0.76 m, height: 0.85 m. The sidewalls of the flume are made of glass, the bottom consists of concrete.

The flow velocity:

The test will make use of two situations:
 1: Average flow velocity
 2: Annual maximum flow velocity

The reasoning and calculations of these velocities can be found in Appendix 7. As the maximum flow velocity in the flume is 1.0 m/s, this will be the maximum condition.

The sediment:

The goal is to simulate the North Sea bottom as is in our two reference situations. For a motivation of choices, see Appendix 8.

Gemini wind park Buitengaats:

Sandy bottom:

- Ø 0.2-0.5 mm (sand),
- Sediment layer height: 5 cm.

Stony bottom (filter layer scour protection):

- Ø 10-20 cm rocks (natural crushed granite)
- Sediment layer height: one layer of rocks.

Borkumse stenen:

Gravel bottom

- Ø 16-22 mm (morena split),
- Sediment layer height: two layers of gravel.

		Average	Annual maximum
Gemini wind park Buitengaats	Sand	0,15 m/s	0,70 m/s
	Rocks		
Borkumse stenen	Gravel	0,30 m/s	+1,00 m/s

Figure 52: Flow velocities.

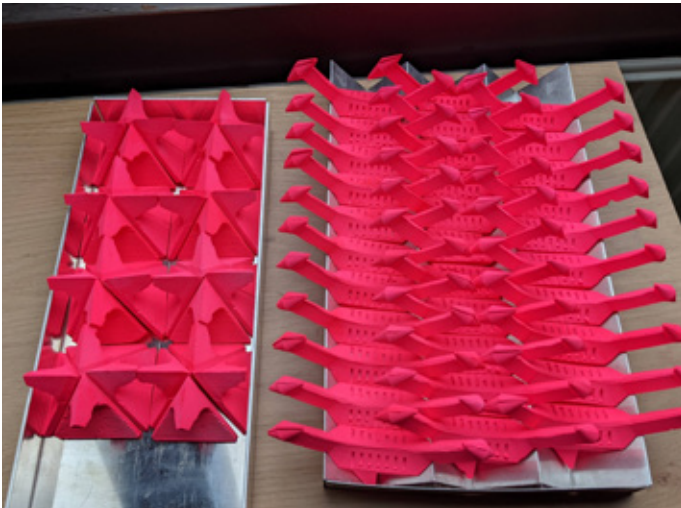

Figure 53: The pink prototypes.

The prototypes:

Six different products were tested: five prototypes and oysters shells.

Two main real-size prototypes were tested; thirty pieces of each are available. They are painted pink or green for visibility. Oyster shells filled with plaster were investigated as to replicate real oysters.



Figure 54: Overview of the prototypes.

Measurements:

The evaluation of the product behaviour will be done mainly by a camera and human evaluation. See figure 55 for an overview of the camera setup. The cameras are positioned so that it films 1.5 meters of the bed from above and 1.5 meters from the side. The cameras can capture specific movements and movements over time. Human evaluation will exist of observations and filling in the 'flume observations sheet', see Appendix 9.

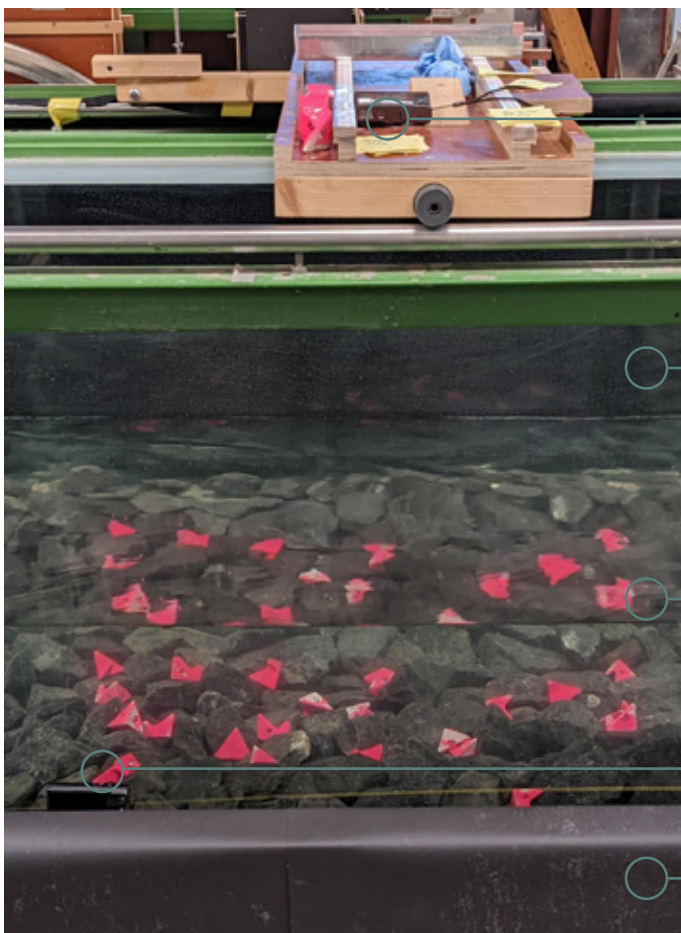

Camera for top-view

Black fabric against the sun

Prototypes

Camera for side-view

Black fabric against reflections

Figure 55: Camera setup.

THE EXPERIMENT

The experiment comprises the following test series, which all will be tested for twenty minutes. Individual tests will be done with five prototypes, to assure credibility.

Sediment	Velocity [m/s]	'Michaëls idee'		'Driehoekpaal'		'Mini'	'Medium'	'Large'
		Individual	Grouped	Individual	Grouped	Individual	Individual	Individual
Gravel	0.30							
	0.35							
	0.40							
	0.45							
	0.50							
	0.55							
	0.60							
	0.65							
	0.70							
	0.75							
	0.80							
	0.85							
	0.90							
	0.95							
1.00								
Rocks	0.15							
	0.20							
	0.25							
	0.30							
	0.35							
	0.40							
	0.45							
	0.50							
	0.55							
	0.60							
Sand	0.15							
	0.20							
	0.25							
	0.30							
	0.35							
	0.40							
	0.45							
	0.50							
	0.55							
	0.60							

Figure 56: Test series.

RESULTS

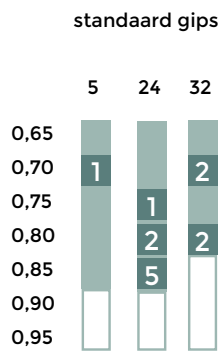
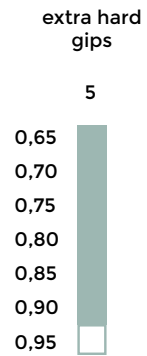
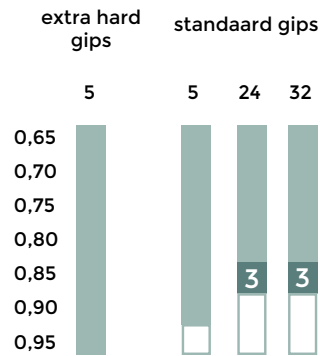
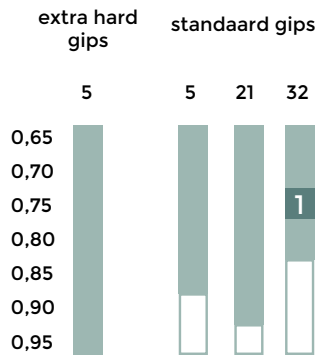
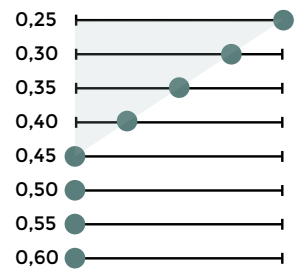
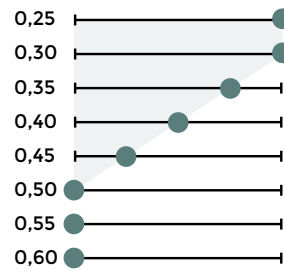
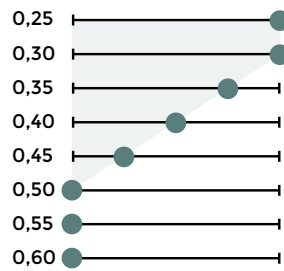
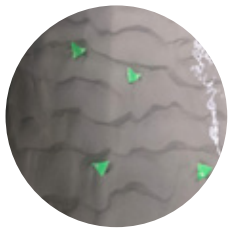
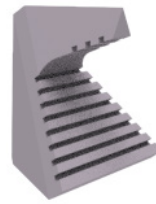

← A group test with 32

Figure 57: Graphic overview of the test results.

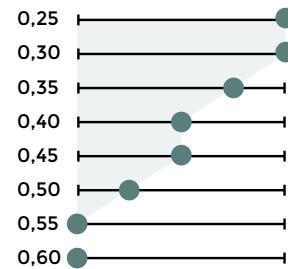
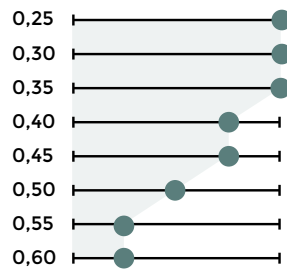
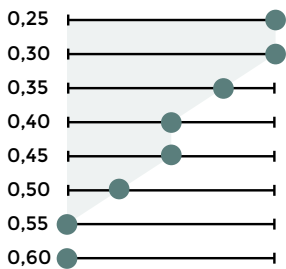
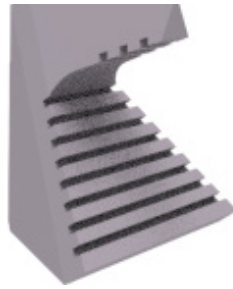
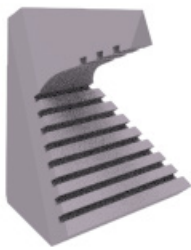

Completely free
 Scour around prod.
 Sand moves on top
 Intermediate burial
 Full burial

↑ Flow velocity

hard stand.

hard stand.

plat leeg

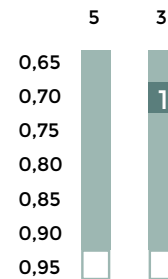
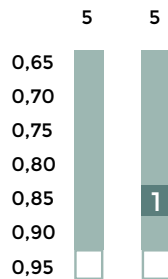

extra hard gips

5

← An individual product was tested five times

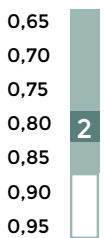

← These velocities yielded no movement

← At this velocity, two products moved more than 15 metres

← These velocities could not be tested

CONCLUSIONS

Six different products were tested in a range of flow velocities, on three different bed compositions. To answer the main research question, the sub-questions are answered first.

Do the products stay above the sediment (have at least 50% of their body above the sediment after twenty minutes)?

Burial by sediment is an only risk on sandy beds; gravel and rocks do not roll over the products in flow velocities up to 1.00 m/s. On sandy beds, sand ripples of about 30 millimetres start to move over products at flow velocities of 0.50 m/s, temporarily burying them. Larger objects experience less influence of sand ripples than smaller objects.

Sediment deposition occurs in the obstacle shadow: low-velocity areas behind obstacles. This is mainly a problem for the products that have their 'critical surface' in the downstream direction. The product 'Michael's idee' orients itself in such a way that the 'legs' are in the downstream direction, leading to sand deposition on the 'critical surface'.

Empty oyster shells experience sand deposition inside their cavity, which is the case at flow velocities of 0.45 m/s for the majority of the shells. A hundred per cent of the shells that move due to the flow, end up orienting their cavity in the direction of the bed, leading to a trapped 'critical surface'.

In conclusion,

- Up to a flow velocity of 0.45 m/s, the products 'Mini' and 'empty oyster shells' stay above the sediment.
- Up to a flow velocity of 0.50 m/s, the products 'Michael's idee' and 'Piramide' stay above the sediment.
- Up to a flow velocity of 0.55 m/s, the products 'Medium' and 'filled oyster shells' stay above the sediment.
- Up to a flow velocity of 0.60 m/s, the product 'Large' stays above the sediment.

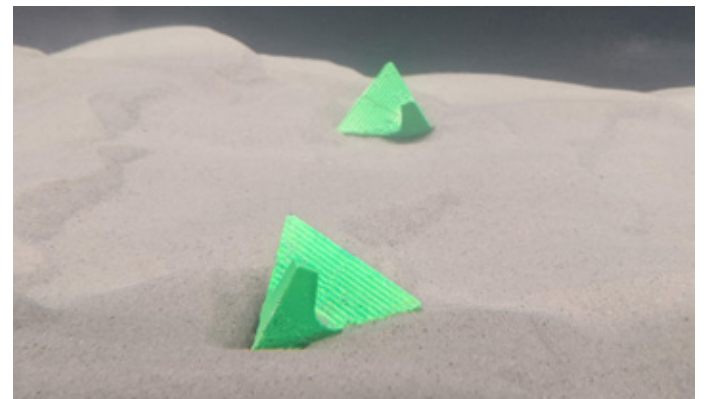
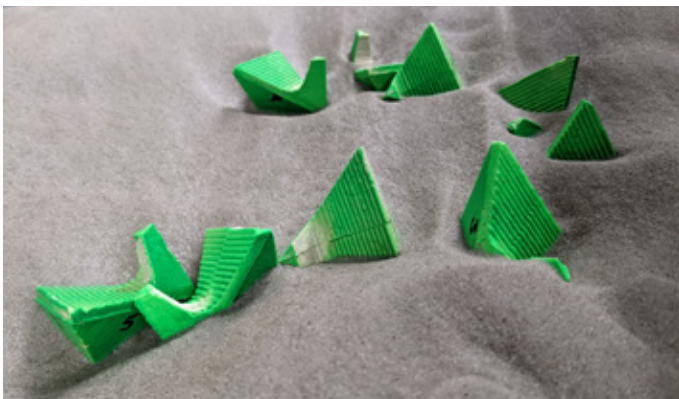

Figure 58 - 61: Prototypes on a sand bed in the flume.

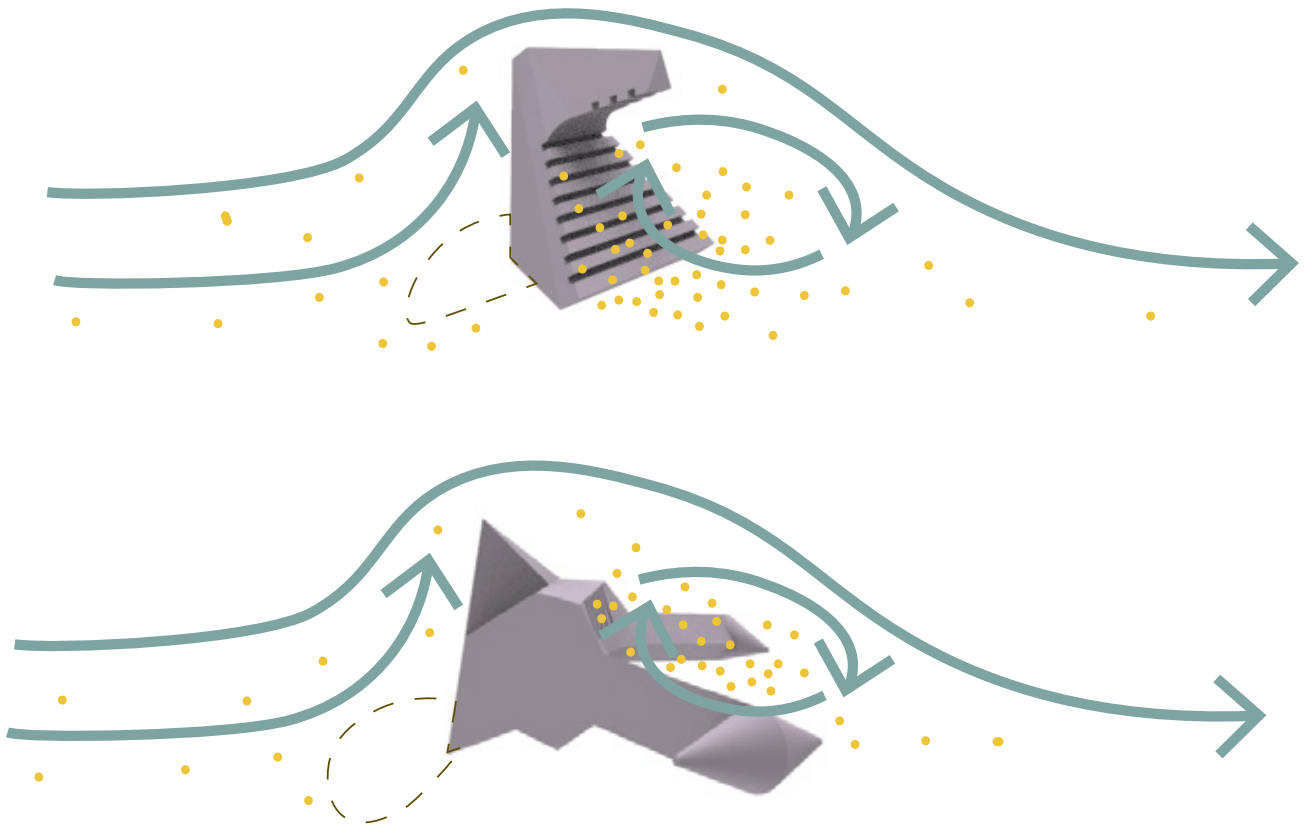

Figure 62: Sediment deposition mechanics.

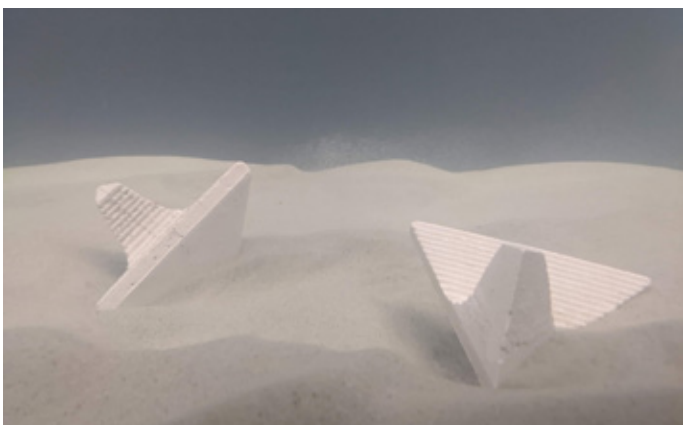
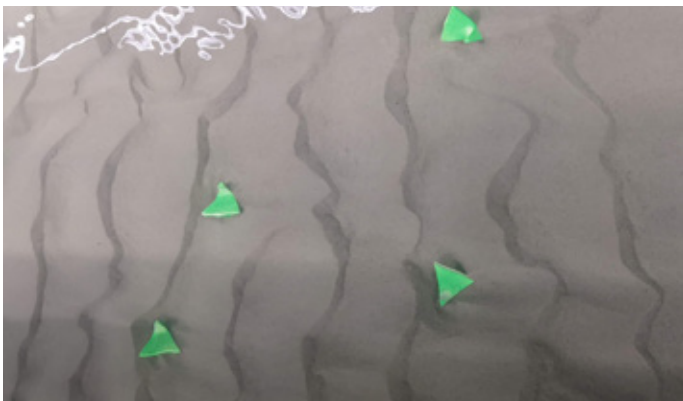

Figure 63 - 67: Prototypes on a sand bed in the flume.

Do the products get in a stable position (products fixed within fifteen meters for at least twenty minutes)?

The rolling of products is only a risk at rocky or gravel beds; products on sandy beds do not tend to roll.

The tests on gravel beds showed that heavier products remain more stable on the bed than lighter ones. All concepts in hard plaster, which are heavier, remained stable up to a flow of 0.9 m/s. Products orient themselves so that they have the least flow resistance. See figure 69-72 to see how they stabilize.

On rocky beds, products stabilize between the rocks up to a flow of 0.85 m/s. The products get stuck in creases and behind edges; their shape contributes to this behaviour.

Figure 68: Products on a rocky bed.
Figure 69 & 71: Orientation of 'Driehoekpaal' in a high flow velocity.
Figure 70 & 72: Orientation of 'Mich. idee' in a high flow velocity.



Does clustering products (two or more that touch each other) improve their stability (products fixed within fifteen meters for at least twenty minutes)?

Clustered products on a gravel bed are less stable than individual products. As the weight of the products is quite low, they take each other in their movement. Figure 78 is exemplary.

On rocky beds, there is no significant difference between grouped products or single products.



How well do submerged oyster reef restoration products perform in water flow?

In conclusion, on sandy bottoms, there is a risk of burial starting at velocities of 0.45 m/s. On rocky and gravel bottoms, all heavy products stay stable up to a flow of 0.85 m/s. Individual products are more stable in water flow than clustered products.

Taking both stability and burial into account, the product 'Large' performs best: larger products get less affected by bed movement, and heavier products are more stable in high flow velocities.

Figure 73 - 77: Products on a sandy bed.
Figure 78: Products flying away.
Figure 79: A broken prototype in normal plaster.

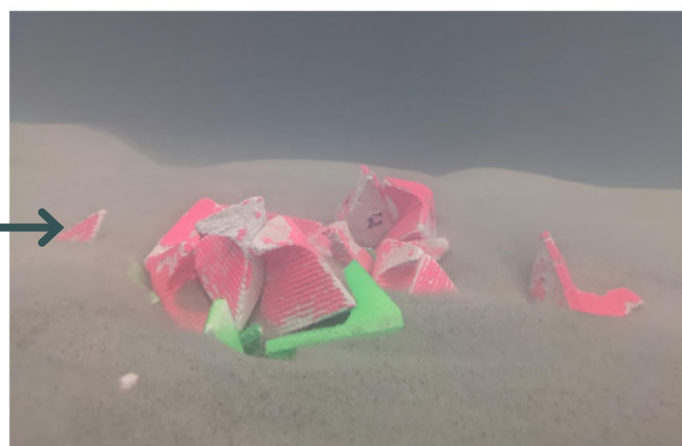
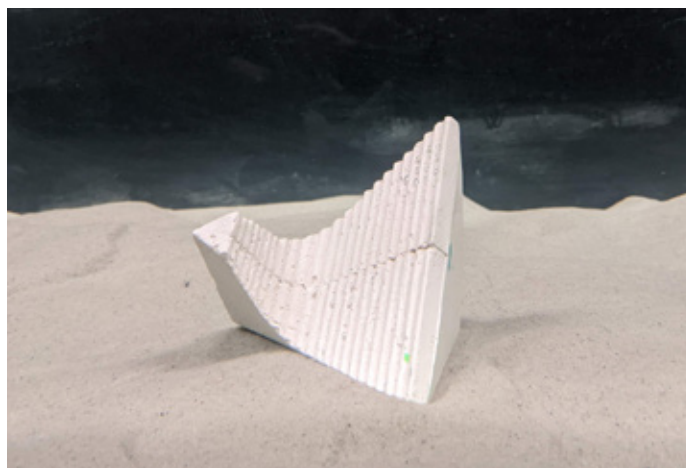

DISCUSSION

This experiment was executed in a flow flume, so there is only flow loading. In normal conditions, waves influence the bed as well. The flume produces a water flow in a single direction; in real conditions, the flow is not that stable and could vary. The tides change direction every six hours, meaning that the water flows in the opposite direction when this happens. This could not be tested in the flume.

Measurements of water flow were done with a debit measurement device: this measures the debit in the pipe that flows all water back to the start of the flume. The flow speed can be calculated based on the water height. Small deviations could occur from day to day, leading to minor impurities in having a stable measurement.

The maximum flow velocity in the flume is 1.00 m/s. There were several factors influencing whether this maximum velocity could be reached. Firstly, the maximum pump power can only be 40% of the total power, which is dependent on the water column height and frequency of the pump. Secondly, the pipe for returning the water must be submerged at all times. At higher velocities, the water level drops behind the weir, exposing the pipe. Both factors should be balanced to reach 1.00 m/s. During the first tests, I did not manage to balance these, which resulted in a lower maximum flow velocity of 0.80-0.85 m/s.

The maximum annual flow conditions at reference location Borkumse stenen are much higher than could be tested. However, as the same design was tested in four different sizes, scaling translations can offer an indication of stability in higher velocities. Product 'Driehoekpaal' is stable at velocities of 0.95 m/s. The product 'Large' is two times larger, so stability in flows of 1.90 m/s can be expected. However, this would be true when neglecting bed properties; the gravel is not scaled, so friction is expected to influence this estimation.

The flume has walls (while the sea does not), which could influence the water flow at the locations close to the wall.

Regarding the sediment, pure sand with the size of 0.2-0.5 millimetres was used. In real conditions, there is a mixture of sand in different grain sizes and clay. Clay is sticky, which results in a more stable bed. Besides, biological components are present on the sea bed, which stabilizes the bed as well.



EMBODIMENT

With regards to the functionality tests, the concept that suited best was the “Driehoekpaal” in the largest size that was tested. In this chapter, this concept is elaborated and a cost price estimation is presented.



Four different surfaces were tested in the flume by laying them for ten minutes on a sandy bed with a water velocity of 0,4 m/s. Disc 1 had a clear flat surface and was used as a reference. No sand remained on this surface. All discs collected sand, except disc 3, which had small

'towers'. In conclusion, small holes and crevices should be avoided, better is to use a flat base with an extruded pattern. According to the test, this should lead to the least amount of sand deposition on the surface, while still providing spatial refuges to larvae.

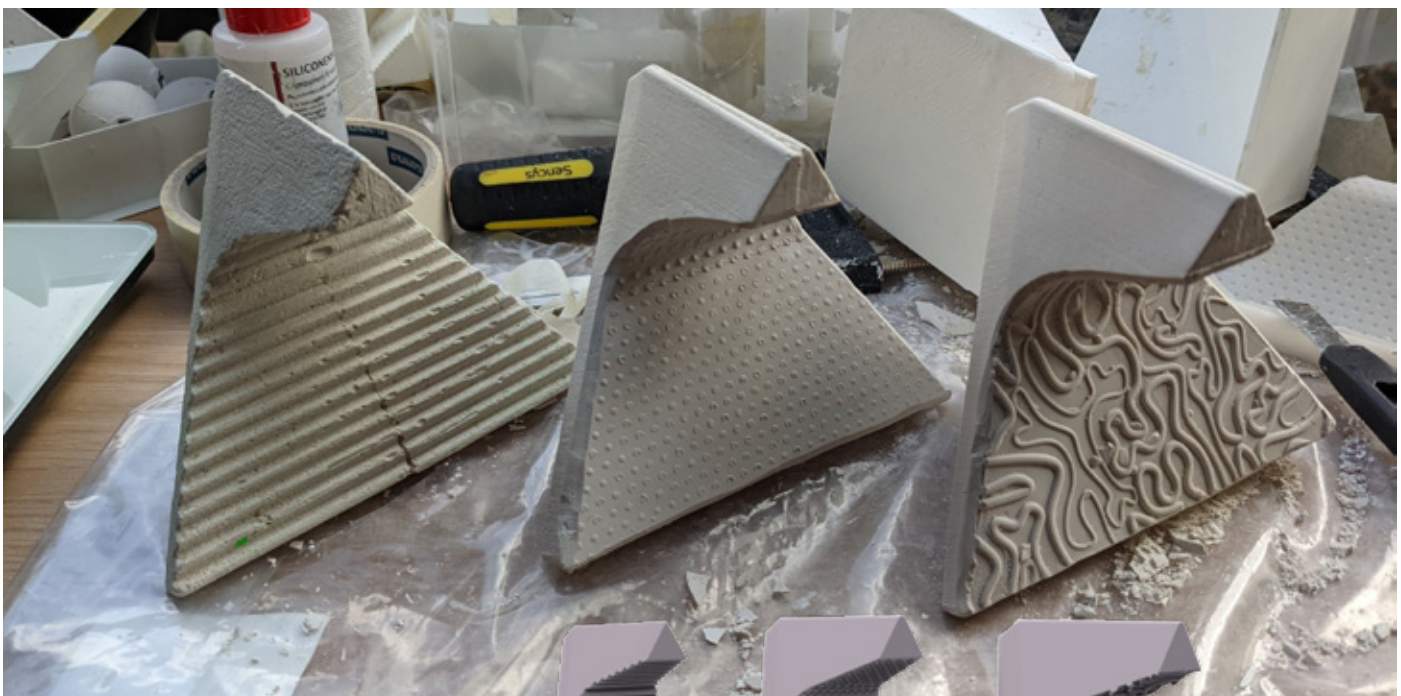
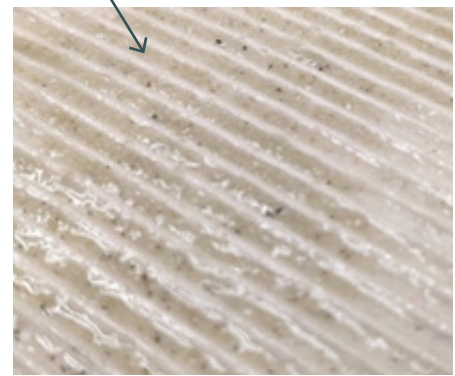
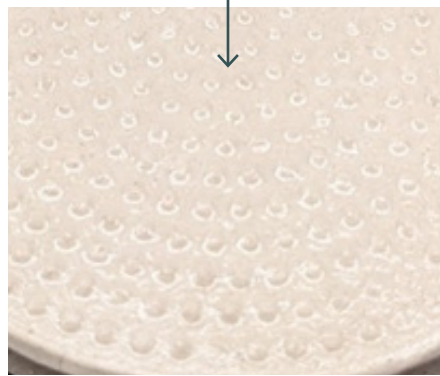
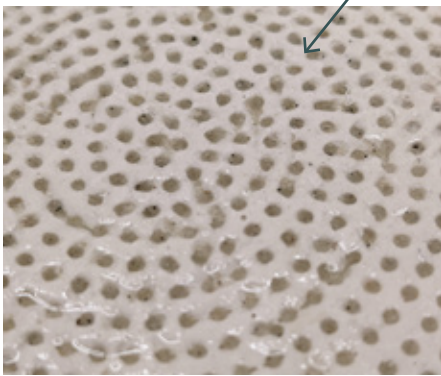
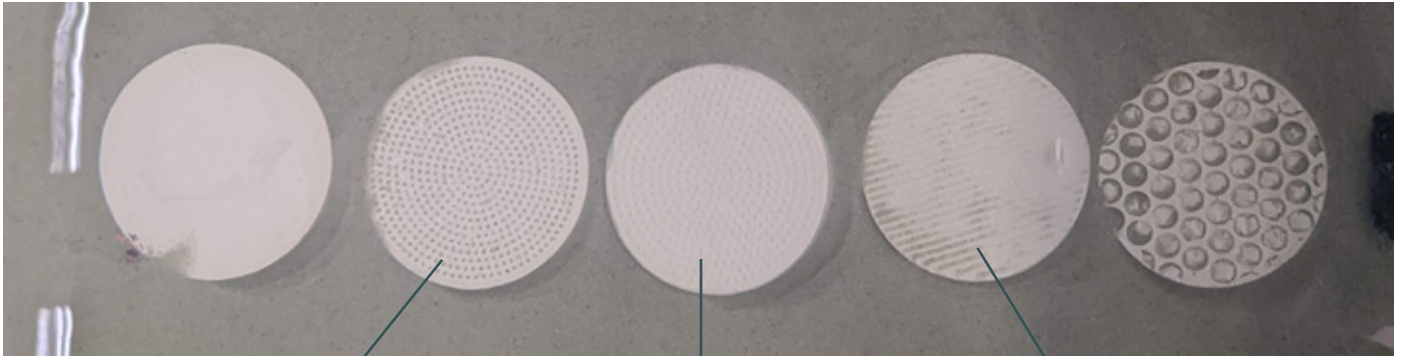
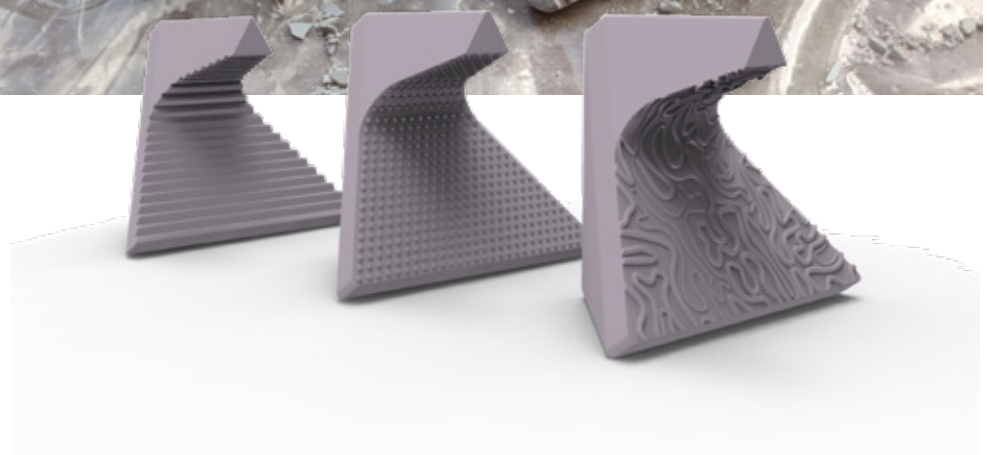

Figure 80: Tested surfaces.
Figure 81 - 83: Results from sand-surface tests.
Figure 84: Prototypes with three different surfaces.
Figure 85: Render of surfaces.



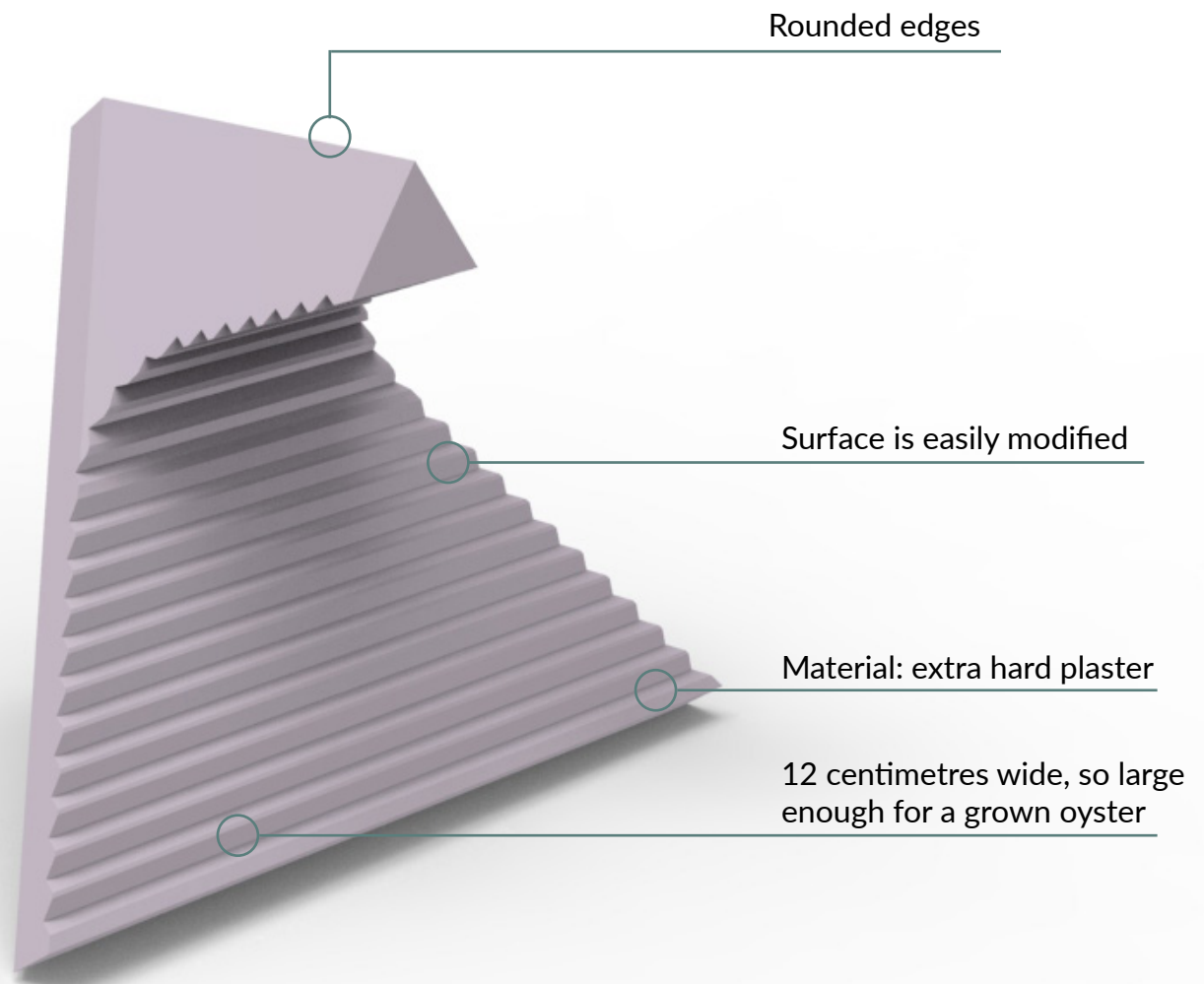

Figure 86: Render of the final product.

COST PRICE ESTIMATION

A rough approximation of the cost price of the product was made based on a series of 500.000 products, following Kals et al. (2019) [64]. See Appendix 10 for the calculation.

The manufacturing price for a single product is estimated at €1,05. This takes into account the production cost of the product assembled in trays, an overhead factor for general operating expenses, and a factor for unforeseen expenses. The selling price is dependent on the direction of the project, for example, will it be sold individually or as part of a restoration project,

and does a profit margin has to be taken into account? Depending on the profit margin, a price between €1,35 and €2,00 is reasonable.

However, this price is for the product only. Purchase costs of oyster larvae need to be taken into account, just as the costs for keeping an aquarium running during settlement, food for larvae, etcetera. Costs of the transportation tray are not included, neither are transportation costs. I have no insight into these costs, but a tenfold increase should be estimated.

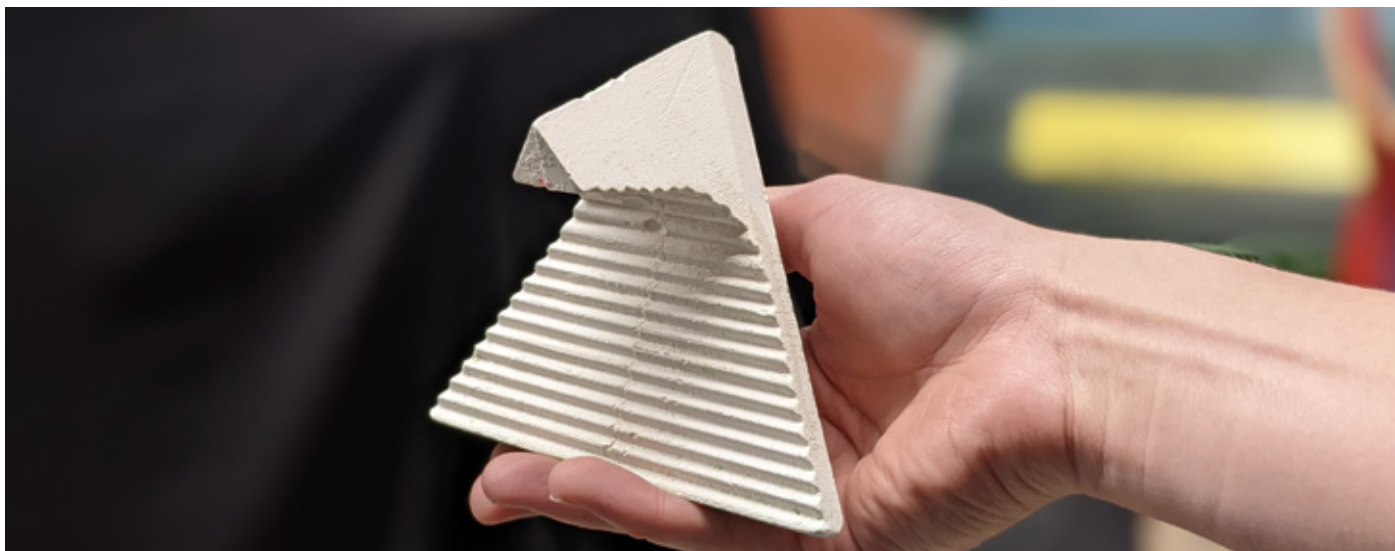

Figure 87: Prototype of the final product.

PRICE PER AREA OF RESTORED REEF

A settlement rate of one larva per 3 cm² can be expected, as are the settlement rates on clamshell material [46]. Soniat et al. (1991) showed higher settlement rates on gypsum products [46], however, the lowest rate is taken as a safety factor.

Our product has a dedicated spat surface of around 60 cm², which means that on average twenty larvae will settle on one product. Between 5-15% of settled oyster spat survives [34, 35]. One product could, therefore, 'deliver' one grown oyster on the sea bed, assuming 5% survival.

A reef is restored when it resembles the situation as was before degradation. With a rate of five oysters per square meter, an area can be called a flat oyster reef. A hectare (10.000 m²) of the flat oyster reef would therefore contain 50.000 oysters.

Consequently, 50.000 products would be needed to restore a hectare of reef. This leads to an estimate of €100.000,- for providing the products to restore a hectare of oyster reef, assuming a product price of €2,-.

As comparison: around 275 reef balls would be needed to recover a hectare of oyster reef [42], which is €275.000 for the reef balls alone.

PRODUCT PRESENTATION

Overview of product qualities.



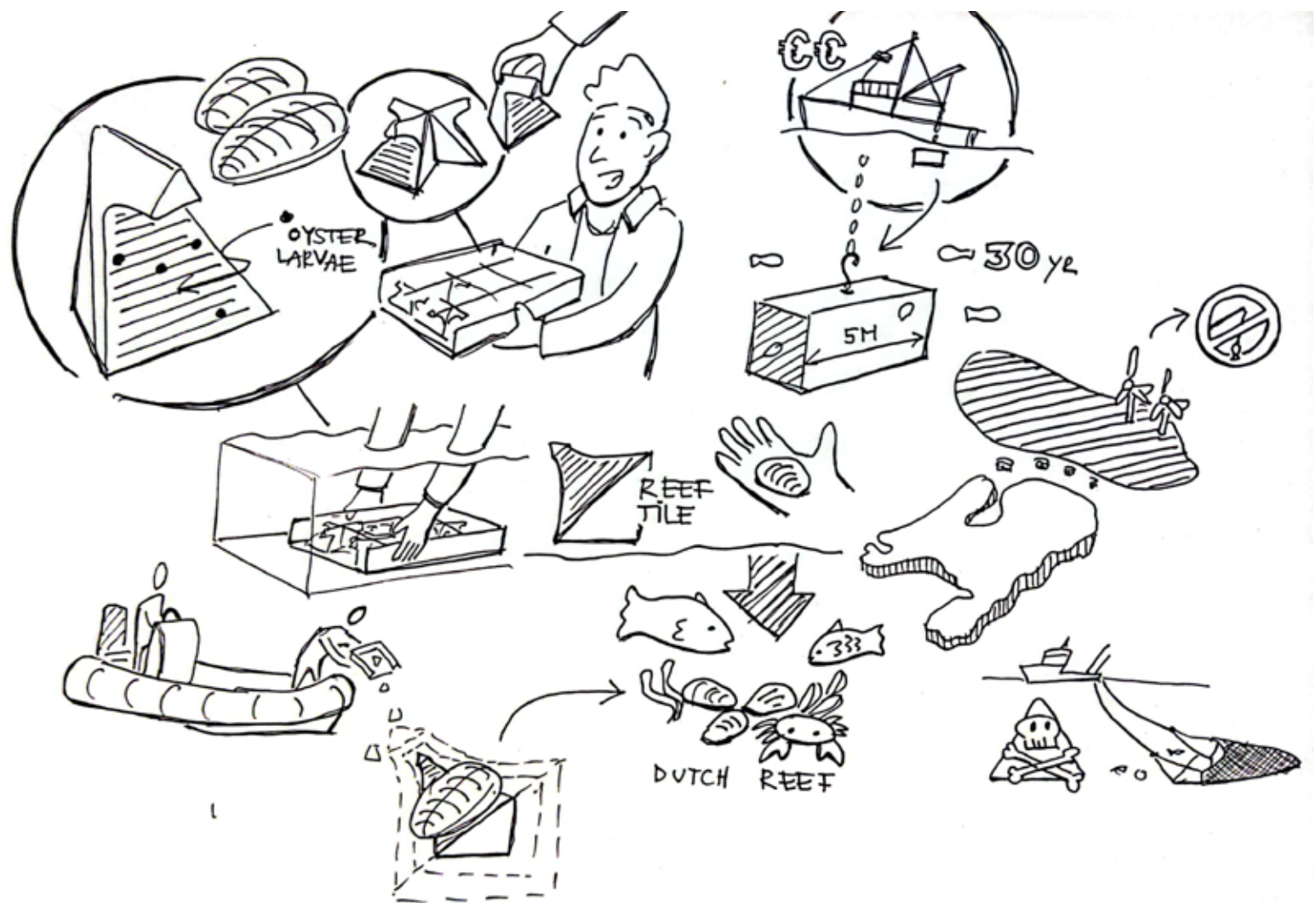

Figure 89: Product qualities.

VALIDATION

In this chapter, the embodied design concept is checked against the key requirements. This involves, among other things, the degradability of the material when taking chemical erosion, mechanical erosion, and bioerosion into account: the product is expected to remain on the sea bed for six months to two years. Secondly, experts' perception of the product in terms of reliability and functionality is discussed.



Natural occurrence of the material



Gypsum plaster is a common constituent of sedimentary marine rocks. Its chemical composition is $\text{CaSO}_4 \cdot 2\text{H}_2\text{O}$ (calcium sulfate dihydrate), which means the main components are calcium and sulfate ions. These are naturally found in the environment.

Biological safety of the material

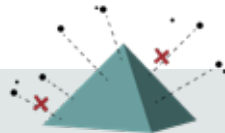

As chemical pollution is not desired, the product should be made out of biologically safe materials. The substance has a good environmental profile and shows no harmful health effects [65].

After degradation, the material will break up into calcium and sulfate ions which are naturally found in the environment. The ions are essential to all living organisms and bioaccumulation is not expected. Organisms can extract calcium from the material, which is beneficial for growth.

Promotion of larvae settlement



Settlement rates of flat oyster larvae on the product have not been tested, as this project was executed out of *Ostrea edulis* breeding season. Also, biofilm growth has not been tested; this will be done by a biologist with the right tools.

However, literature research revealed that calcareous materials are preferred by *Ostrea edulis* larvae (e.g. [46]) and grooves and rough rock-like surface textures are preferred [49, 50]. Gypsum plaster is a calcareous material and the

product's surface consists of grooves suited for spat (which are around five millimetres).

Besides, suggested is that larvae avoid light exposition by fixing on more shadowed and protected areas [54-56]; the composition of products in a tray provides several options for creating shadowed areas. Larval fixation is enhanced when substrates are vertical [49]; the products provide options for sub-cryptic settlement in two orientations.

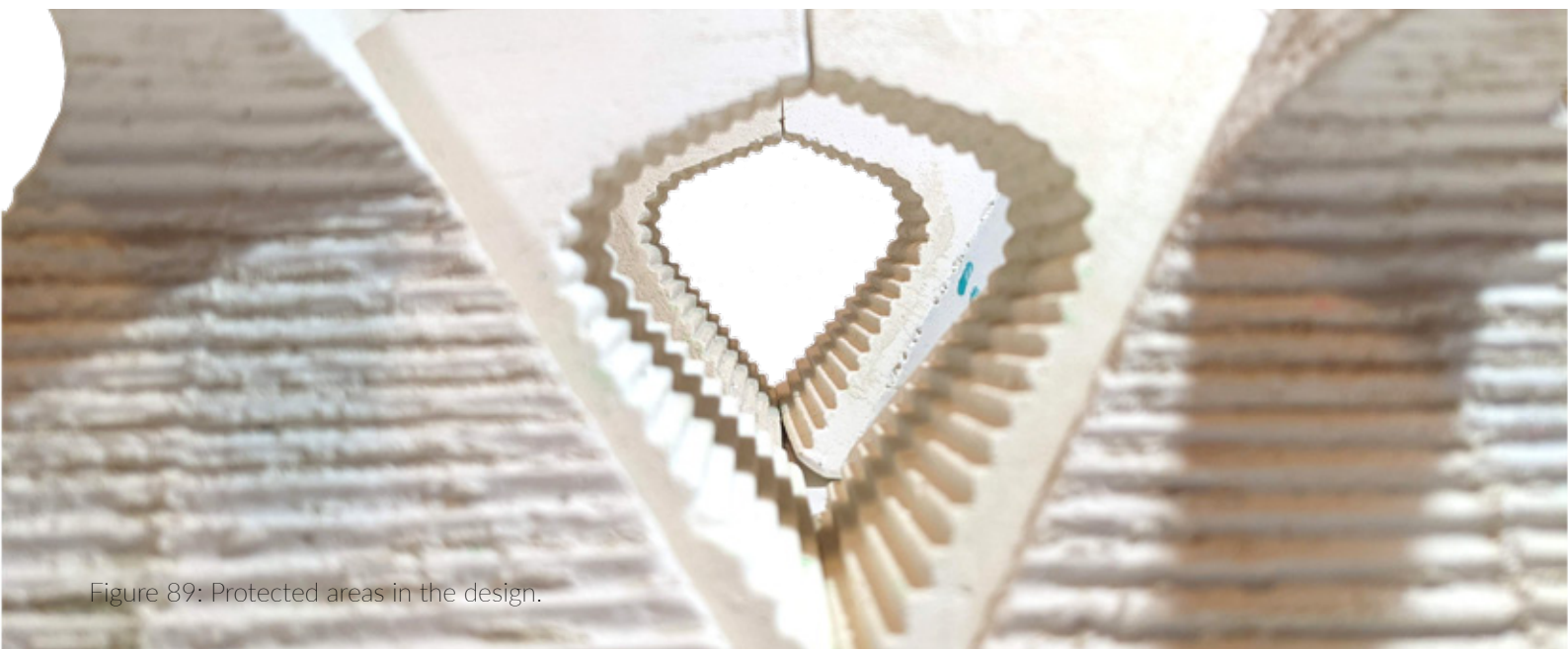

Figure 89: Protected areas in the design.

Holding and examining the product without touching settled spat

The product provides a 'handle' for safely grabbing the product without touching spat. This is useful for examining settled larvae when the product is still in aquarium settings.

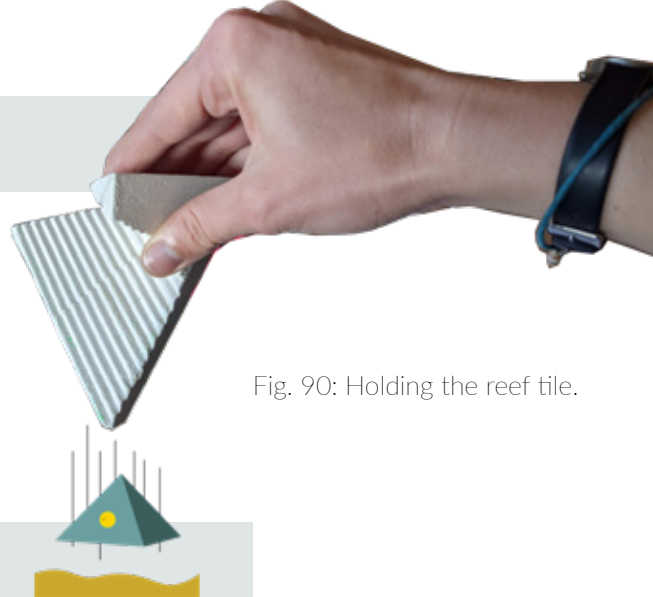

Fig. 90: Holding the reef tile.

Sinking to the sea bottom

With a density of around 1900 kg/m^3 , the material's density is larger than seawater ($>1023.6 \text{ kg/m}^3$), meaning that the product sinks to the sea bottom.



Staying in place underwater

The flume experiments provided us with insight into the stability of the products. The experiments on a gravel bed indicated a resistance against rolling in water flows up to 1.9 m/s . However, this should be validated with a field test.



Protection of larvae

The product protects larvae against larger predators by providing a surface that has a rough texture.



Figure 91: Refuges by spatial surface design.

Staying above the sediment



The risk of burial is dependent on the sediment characteristics per location. Therefore, definitive validation cannot be given. The flume experiments indicated risk by burial of different sediment bottoms. No burial is expected on gravel or stone bottoms. Burial can occur on sandy bottoms, dependent on the type and grain size of sediment. For sand of 0.2-0.5 millimetres, full burial is not expected below flow rates of 0.6 m/s.

The product is designed in such a way that the dedicated surface for larvae could never touch the bottom, which increases the possibility of staying above the sediment.

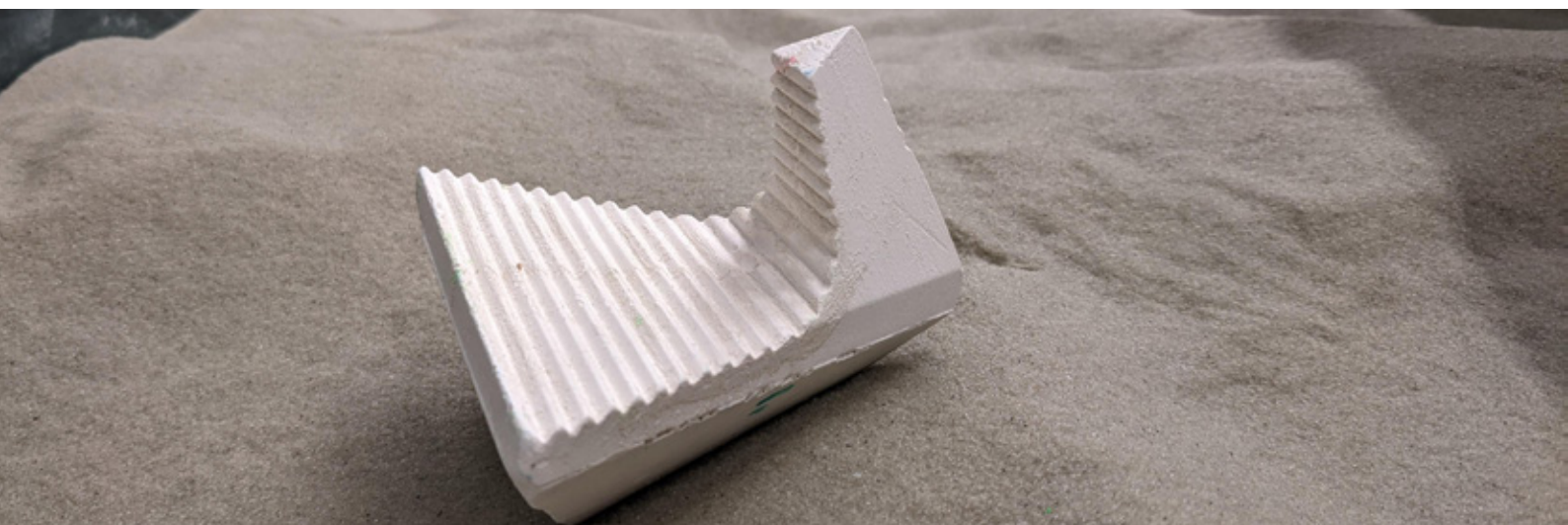

Figure 92: Reef tile on top of sand.

Hosting a grown oyster

+6 mths



Mature oysters are around five centimetres long [21] and fit on the dedicated surface of the product.



Figure 93: Mature oysters on reef tile.

+6 mths

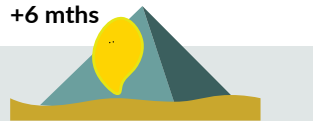

Degradability of the material

'Degradation' indicates the decline in the condition, quality, or functionality of a material. The full degradability of our plaster material is expected to be between six months and two years; the requirement of the product existing minimally six months on the sea bottom is therefore expected to be met. The degradability is initiated by three factors: chemical erosion, mechanical erosion, and bioerosion.

Chemical erosion: dissolution

Dissolution is expected to be the most important factor influencing the lifetime of the product. A small experiment regarding the dissolution of gypsum plaster was executed, however, its results turned out to be unusable due to large influences of the setup of the experiment. See Appendix 11 for the experimental setup and results.

Literature review revealed inconsistencies in dissolution rates for gypsum plaster between several studies. Also, a range of possibilities could have influenced these experimental rates, for example, no consistent environment was used and no consistent specimen (dissolution coefficients are dependent on the surface area of a specimen). Also, the flow variables addressed using gypsum dissolution are diverse and often nonspecific, for instance, 'flow intensity', 'turbulence intensity', or 'water motion' is described as variable [66]. This makes

a reliable output difficult. For this reason, a range of outcomes is presented instead of a single one.

The rate of dissolution was calculated using the Noyes-Whitney equation.

$$dm/dt = k A (C_s - C_t)$$

where,

dm/dt is the dissolution rate, the change in mass (m) of the solute per time (t) [g/sec], k is the mass transfer coefficient [m/s], A the exposed area of the solid [m^2], $(C_s - C_t)$ is the concentration difference between the saturation solubility and in the saturation of the bulk liquid at given time t .

Firstly, the influence of flow rate. The dissolution rate increases with an increase in flow velocity [67]. Howerton & Boyd (1992) even saw a linear correlation between weight loss and increasing water velocity [68]. However, Porter et al. (2000) has shown that gypsum dissolution is not correlated with water flow in fluctuating and mixed flow environments; flow rate is not universally integrated into dissolution [66]. Aljubouri & Al-Kawaz (2007) determined a change of 0.15×10^{-5} m/s in k for each 0.1 m/s change in flow velocity [67]. In conclusion, there is an increase in dissolution rate when the flow rate increases, but there is no consensus on a specific value.



Figure 94: At-home dissolution experiment.

In the Dutch North Sea, on our reference location, average flow rates are around 0.1 m/s, while the annual maximum is around 0.7 m/s.

Secondly, the influence of water composition. The salinity and saturation of the body of water affect dissolution rate; ion-pairing effects reduce the activity of ions and result in increased solubility [69]. An increase in salinity leads to an increase in dissolution rate, according to Howerton & Boyd (1992) [68]. However, a higher saturation rate, which is expected in seawater environments, will counteract the effects, as a body of water can become (nearly) saturated, retarding the dissolution [70].

Thirdly, the influence of temperature. Increased temperatures accelerate the dissolution rates of gypsum plaster [71]. Aljubouri & Al-Kawaz (2007) determined a change of 0.006×10^{-5} m/s in k for each 1° C change in temperature [67].

The water temperature in the North Sea ranges from 5°C in winter to 18°C in summer [72]. The dissolution is expected to retard in winter.

Finally, the influence of the surface area. A larger surface area leads to an increase in solubility. The materials used in literature are either spheres or cubes, with smooth surfaces.

Taking these influences into account, a theoretical estimation was made regarding the dissolution time of the product. Experimental dissolution data were converted using conversion rates from Aljubouri & Al-Kawaz (2007) to approximate the expected environmental conditions [67]. See Appendix 12 for an overview of the data. The expected average yearly temperature is 13°C, the average flow velocity is 0.15 m/s. Water composition was not taken into account. Dissolution time in extreme conditions was also estimated, see Appendix 13 for the results.

The dissolution time of our plaster material is expected to be between six months and two years. I advise executing an experiment to retrieve dissolution constants in the expected environment, as theoretical calculations of dissolution rate constants are rarely adequate.

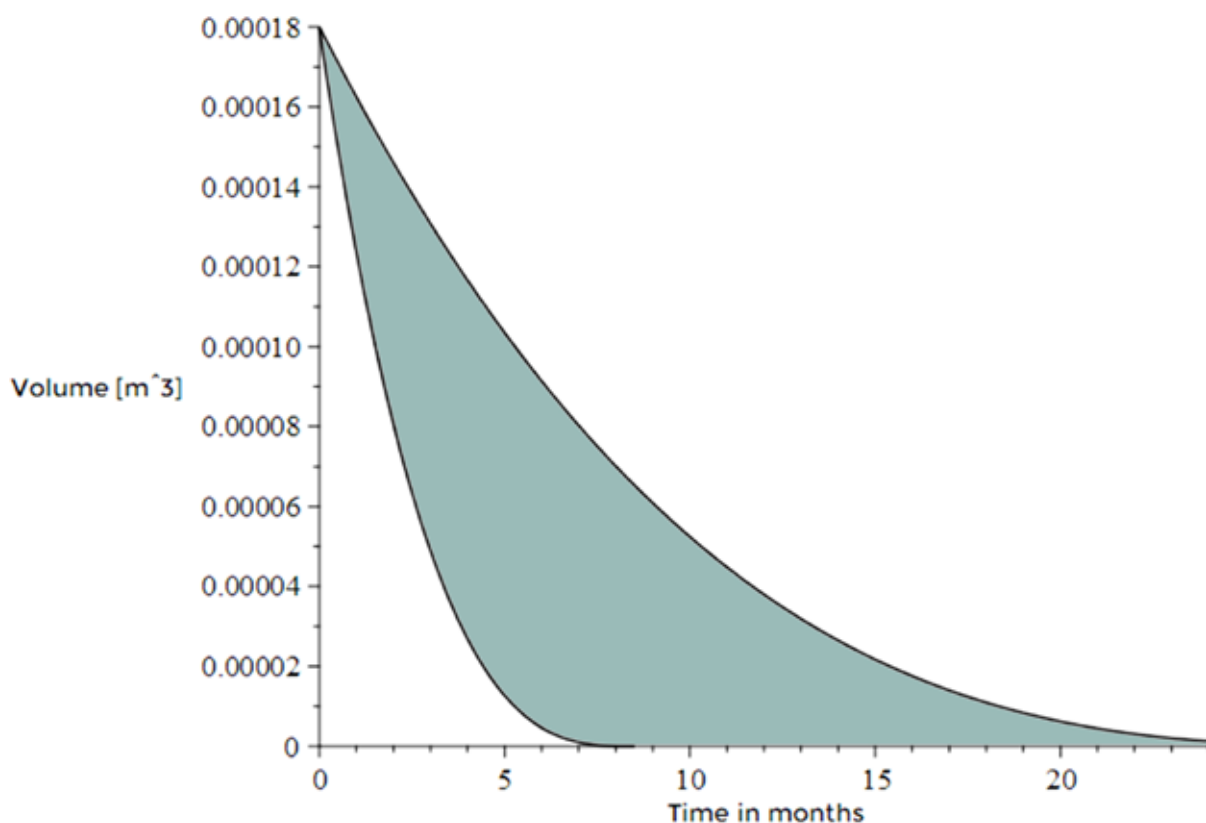

Figure 95: Expected dissolution time reef tile.

Mechanical erosion: abrasion and wear

Abrasion is the process of erosion caused by friction at the surface: for example friction with water or sediment. In our case, abrasion is dependent on orientation-, flow-, and sediment characteristics. There is a general trend of increased abrasion in relation to increased sediment size and increased flow velocity [73].

It is difficult to assume the effect of abrasion, as the final environmental conditions are unknown and no data on abrasion rates of submerged plaster is present. The abrasion is expected to be in the range of 0.4 - 1.0 mm per year (as for limestone), dependent on hydrodynamic conditions [74, 75]. This value is insignificant compared to chemical erosion, so it is not taken into account for the final lifetime estimation.

Below (figure 96) is a view of expected locations of abrasion of the product, derived from the usage of prototypes during flume experiments. This could function as an example for abrasion expectations in a real application. We see the rounding of edges and the surface. sand induced abrasion can cause smoothing of the surface.

Wear is the result of human handling of the product, for instance touching and transporting. This influence is expected to be insignificant compared to other factors.

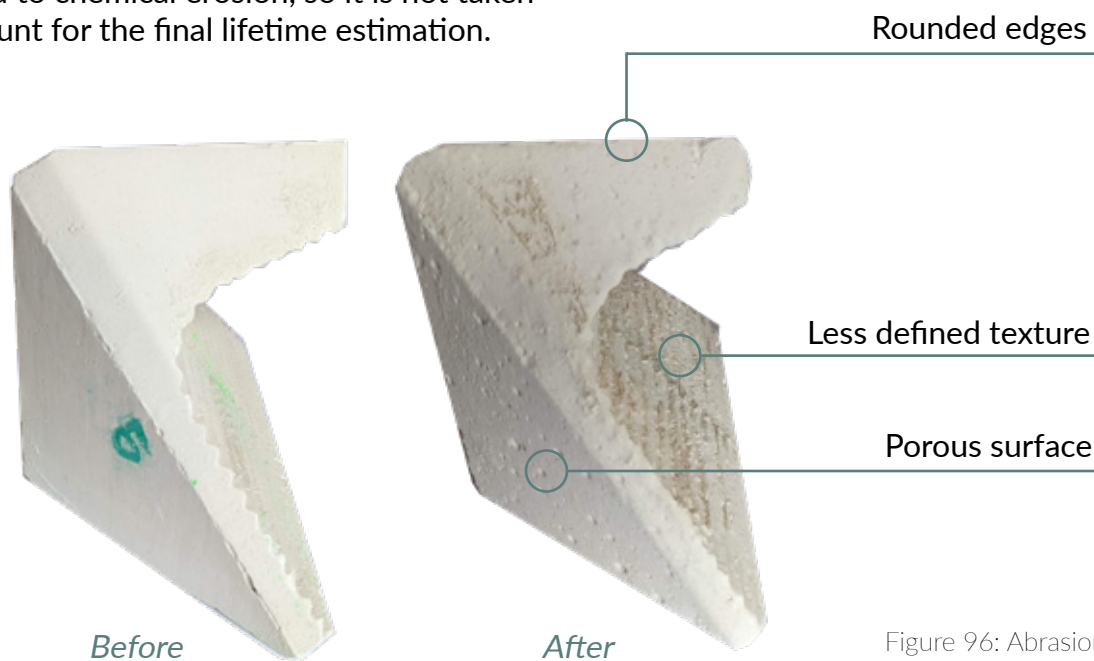

Bioerosion

Biodegradation is the breakdown of organic matter by microorganisms, such as bacteria and fungi [76]. The substance is an inorganic salt and hence no biodegradation will occur.

Biofouling: Most of the organisms belonging to the biofouling communities are epiphytic; they just live on the surface, without going deep inside the material [77], i.e. algae, bacteria, and fungi are micro-perforating organisms. These are not expected to influence the product's lifetime.

Boring sponges (*Cliona celata*), however, can go deep inside a material: these organisms bore into calcareous substrates, including for example

the shells of bivalves (oysters). They weaken or destroy a substrate by hollowing out tunnels [78]. They are expected to bore into the plaster products, leading to faster degradation.

However, their presence is a greater threat to the survival of the young oysters than the degradation of their substrate is. Since the presence of boring sponges is not a given, we will not take this type of erosion into account for our final assumption on product lifetime.

Conclusion about degradability

Taking all these factors into account, the full degradability of our plaster material is expected to be between six months and two years. Conditions of maximum erosion (episodic storm-induced erosion) are not likely to occur consistently in the field. Six months is the minimally required lifetime of the product, which is estimated to be met.

EXPERTS' PERCEPTION

Interviews with experts in different fields provided me with their opinion on the product. Their approval is a proper indication of a successful product.

Renate Olie is a restoration expert at De Rijke Noordzee. They were enthusiastic about the largest prototype; they saw the 'Driehoekpaal' in four sizes. As the large prototype is bulkier, they perceived the design as stable and trustworthy. They believe this method could be successful.

Oscar Bos is a marine ecologist specializing in the Dutch North Sea. They were enthusiastic about the idea of letting the oyster larvae grow up in their final conditions, as they adapt to their environment: e.g. an oyster will grow a stronger and thicker shell in higher flow velocities, leading to a higher survival rate. They proposed a midway between letting the spat grow in aquarium conditions, as more will survive the critical first weeks, and become large enough to survive in the wild and still be able to adapt to the environment.

Bas Hofland is a hydraulic engineer at the TU Delft. They advise, when seeding products near to monopiles, to place these as far from the pile as possible, in the outer ring of the scour protection. The further away from the monopile, the least adverse effects can be felt (e.g. higher flow velocity). Besides, it is best to place any structure out of the longitudinal axis of the tidal currents: the flow velocity will be highest on this axis. To decrease scour effects, they proposed to round the sharp edges of the product. They believe the flume tests are a proper indication of performance, which allow the product to be tested in the field.

Tim Raaijmakers is an offshore engineer at Deltares. Together with Oscar Bos, they researched the effect of both wave, tide, and current forces on mature oysters and empty oyster shells. They found that both living oysters and oyster shells are susceptible to movement, already at flow rates below what could be expected at a large storm. Therefore, they conclude that the location for the placement of oysters is a significant factor in the success of the restoration, as some locations are more sheltered. They expect that placing empty oyster shells alone will be challenging, due to their motion underwater. Therefore, they were enthusiastic about a more stable product.

In their opinion, the largest challenges that restoration practices face are about making the reefs self-sustaining and about finding methods to monitor restoration practices. Finally, they believe that all projects that are involved with reef restoration would benefit from cooperating with (offshore) engineers to predict the impact of certain methods.

In conclusion, all design criteria are expected to be met, motivated by data from literature and experiments. The experts that shared their opinion, showed trust in the product and restoration method and believe that the product is ready for field tests.

CONCLUSIONS

The question of whether this is what is needed to restore Dutch native oyster reefs is answered in this chapter. The viability, feasibility, desirability, and ethical side of the product are discussed.



DESIRABILITY

This product is desirable, as the current practices have an insignificant impact and have several drawbacks. Our product is the answer to the drawbacks: there is no need for removal, as the product degrades. They are small, so no large vessels are needed for transport, and they fit into regular aquaria to let larvae settle. As the products degrade underwater, the natural habitats in the North Sea are altered as little as possible, which is desired by legal regulations.

This also has the advantage that exotics are being attracted as little as possible. The product is cheaper than current methods, for instance, the product cost for the restoration of a hectare of reef with reef tiles is €100.000, compared to the product costs of €275.000 for restoration of the same area by reef balls.



Figure 97: The reef tile presented.

FEASIBILITY:

This is a low-cost, low-tech, easy-to-understand product that could be produced anywhere in the world, because of the wide availability of the material and low complexity of the production. Current systems are present, so this

product could be readily implemented; it is not dependent on coming innovations. The product has proven in laboratory tests that it remains stable up to 1.90 m/s, which shows this is a feasible way to let oysters grow up on sea bed.



Figure 98: Atmospheric image of the flume experiment.

VIABILITY

The product could be used for a range of sessile organisms, and therefore in a variety of (worldwide) locations. Everywhere, reefs are degrading and this product could assist

restoration in all of these locations. These options can contribute to the long-term growth and expansion of Blue Linked and the restoration method.

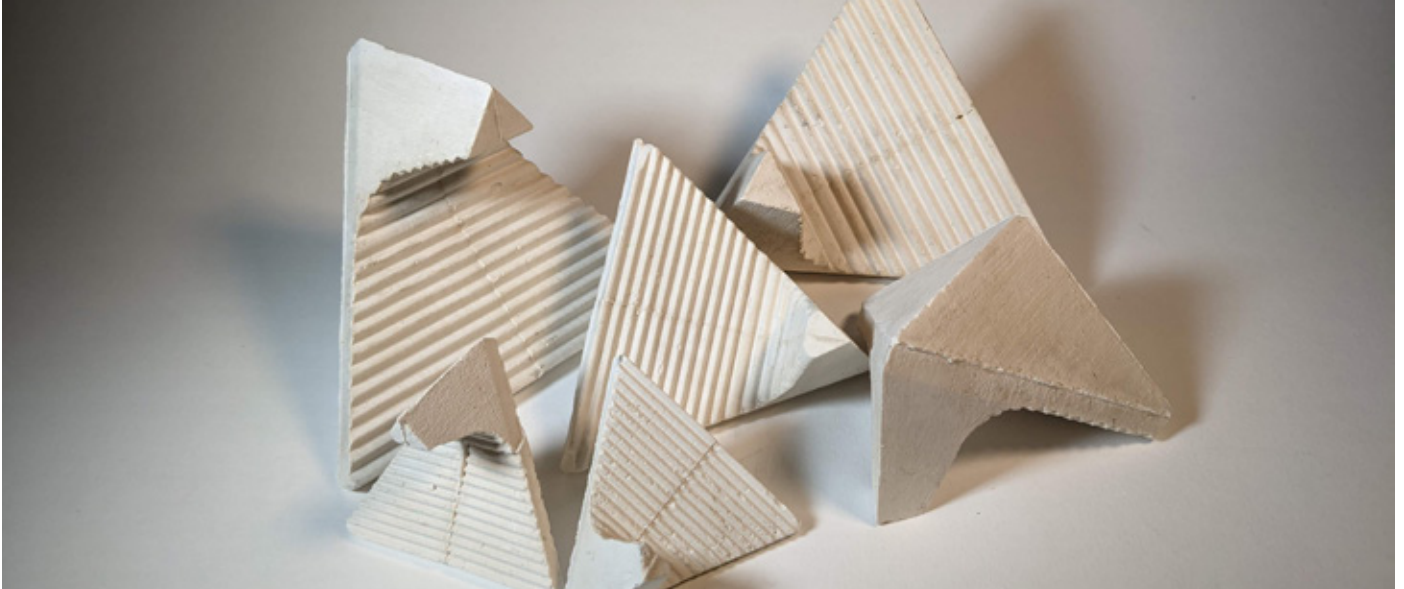

Figure 99 & 100: Three size of the reef tile.

ETHICS

Should we be doing this? Do we really need this in our world? I added this point, as this becomes more and more important for our design sector. If something can checklist all of the above, still the question exists whether the product improves the quality of life for all people, regenerates our environment, and ensures inclusion. For this project, it is very clear to me that we should be doing this.



In conclusion, a product has been designed that can enable the restoration of oyster reefs. With this product, large areas of reef can be restored in an effective and minimally invasive manner.

The final product promotes larvae settlement on the product and allows people to touch the product without touching settled larvae. The product sinks to the sea bottom and stays in place as much as possible, which entails resisting water flow up to 1.90 m/s. The design protects larvae against larger predators and makes sure they stay above the sediment. Finally, the product is large enough for a grown oyster and persists for at least one year on the seabed, after which the naturally occurring material degrades into biologically safe components.

DISCUSSION AND RECOMMENDATIONS

This chapter describes the recommendations on the next steps for this project, both organizational, strategic, as about the product itself. The main recommendation is to continue this project with tests in a natural environment.



TECHNICAL FACTORS

Firstly, the product's performance should be investigated further: a field test will show whether the product performs well on the sea bottom. This test could be done with or without settled spat. Having the product tested in a real environment will provide new insights and increase the reliability of the product, which is a necessity when doing large-scale restoration is the aim.

Secondly, the material should be tested and optimized. As the expected theoretical lifetime of the product is between six months to two years, a large range, the lifetime of the product should be experimentally established.

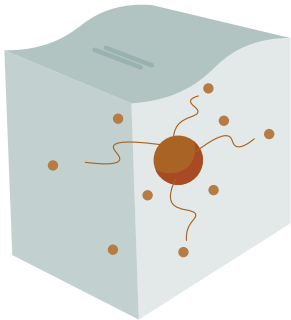

Thirdly, the product itself is not fully developed yet, as the transport tray needs to be designed. The dimension of the transporting tray should be investigated, and how many products would fit on the tray. This is dependent on transportation guidelines, e.g. what the usual dimensions are for transporting on a small boat, and the dimensions of the aquaria of oyster breeders. Whether the settled spat need flowing water during transport also needs to be investigated. If so, a box that keeps water flowing should be designed.

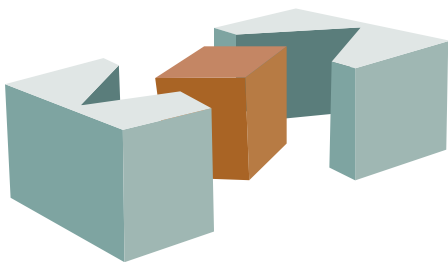

Interesting additions could be examined, for instance, whether crushed oyster shells are beneficial, or whether certain bio-based ingredients speed up the process of growing a biofilm. Manning et al. (2019) found that adding pine sawdust to substrates helps to control predation on *Crassostrea virginica* larvae [79]; this would be interesting to examine as well.

Finally, the industrialization of the product should be elaborated: efficiently producing the product in large quantities. However, this only makes sense after the field test and material tests, as iterations could be done.

BIOLOGICAL FACTORS

Growing a biofilm is seen as an important factor for oyster larvae settlement [7]. Reeves et al. found that the density of settling oyster larvae increased with the age of biofilm on a substrate with an optimum when biofilm had developed for 4 weeks (when it had the greatest biomass) [22]. It should be investigated how to effectively make the biofilm on the product's surface.

The products should be tested on settlement rates of oyster larvae. This provides insight into the placement of substrate or material composition. Settlement tests with other sessile organisms could be executed as well, so the product could readily expand its work area.

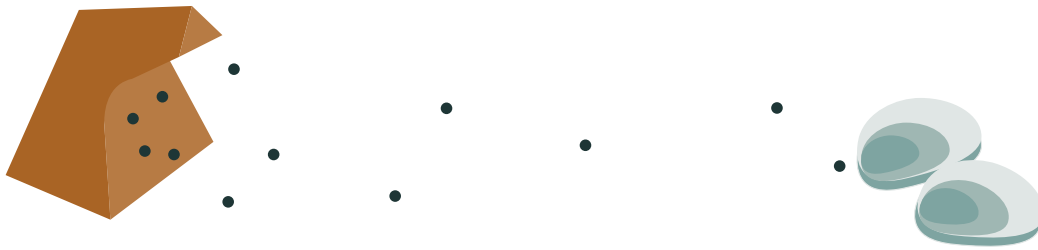

ORGANIZATIONAL FACTORS

What partnerships are needed to prepare and evaluate the field test? When the reef tiles are being sown, how can the effectiveness be evaluated? When to evaluate?

As many wild oysters are contaminated with *Bonamia* (a disease), it should be investigated how or where to acquire disease-free oysters or oyster larvae.

It should be decided how to organize the settling process: how many products could a single aquarium host and prepare? How many oyster farms should be included? What would the planning be, from receiving oyster larvae to seeding out the reef tiles?



STRATEGIC FACTORS

As The Netherlands has many regulations that need to be followed, it could be a strategic decision to move the restoration practices to other countries. When the project has proven its success, it might be easier to access the Dutch Seas with this project.

Beneficial partnerships could be explored, for example with funding parties, companies that have valuable contacts, or maybe universities. A strategic plan on how to get the attention of funding parties could be made. The marketing of this product could be investigated.



LARGER PICTURE

To get the Dutch oyster reefs to thrive, more than just this product is needed.

Firstly, increasing awareness of the need for sustainable practices is necessary. Even while the wild native oyster beds are probably one of the most endangered marine habitats in Europe, there does not seem to be a specific protection measure nor widespread restorative management [2]. Policymakers, as well as the majority of the Netherlands, do not seem to be aware of the threat.

Secondly, current environmental impacts should be mitigated. For example, a more eco-friendly way of bottom fishing should become common practice, as bottom trawlers destroy everything on the sea bottom [2]. Changes made to the environment (e.g. coastal development) that lead to habitat loss should provide the marine wildlife with alternatives, for example by assigning more designated locations for ecosystem restoration.



REFLECTION AND ACKNOWLEDGEMENTS

For a proper reflection on this project, I used the triple-loop learning reflection method. The triple-loop learning model, developed by Argyris and Schön (1974), engages in three levels of learning about successful results and how these can be achieved [80]. In summary, the three core questions addressed with this model are:

1. Are we doing things right? Do we need to improve our actions?
2. Are we doing the right things? Do we need to change our choices in what we do and how we do this?
3. How do we decide what is right? Do we need to change the principles, theories, or visions that underpin our decisions for change?



1. DID I DO THINGS RIGHT?

This loop is about single actions and their reactions. For example, when I could not find the answer to the expected lifetime of the product (problem), I approached a professor from chemical engineering to help me find a way to solve it (solution).

The following examples illustrate things that I did not do right and had to solve. Casting gypsum plaster in 3D printed molds did not work, so I had to find alternatives: casting in silicone and using a demolding agent. The plaster I chose for the prototypes appeared to be too brittle, so I switched to a harder type of plaster. The results from the dissolution experiment turned out to be unusable, as I found out that I set up aspects of the experiment wrongly when interpreting the results. The solution to this was to spend more time on finding data in literature and showing a range of answers instead of a single answer.

All these single adjustments were great to learn from. However, most of the reflection I did during this project fits into the next category.

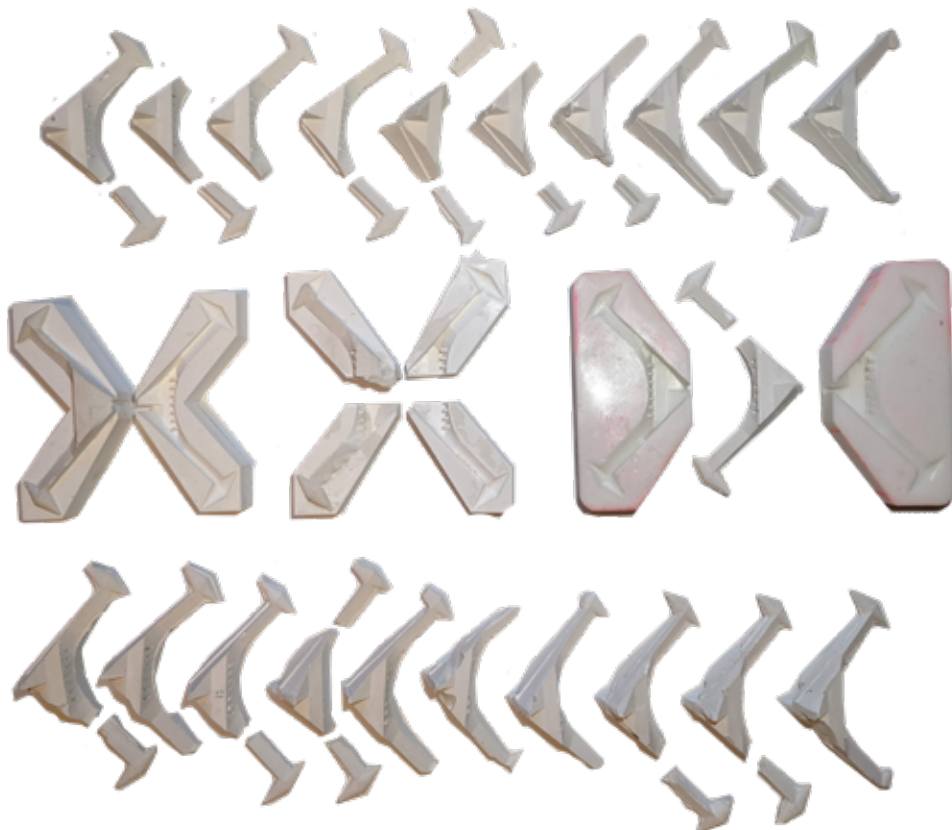
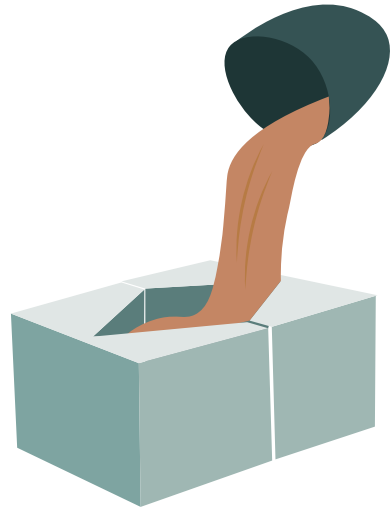

Figure 101: Prototypes that broke and molds that malfunctioned.

2. DID I DO THE RIGHT THINGS?

This second question reflects on the practices. For example, when encountering a problem, the underlying causes are being examined, instead of only symptom management.

When reflecting on the techniques and tools used for this project, I can conclude that a methodological approach has helped me gain structure in the project. In that sense, I did the right things; in my opinion, this approach increased the scientific quality of the project. Substantiating choices and directions was also valuable for my confidence in the results and the success of the project itself.

One of the ambitions that I phrased at the beginning of this project involved proving that I can be hands-on in an individual project, as I tend to stay in the theoretical part for the majority of the project. I am happy that I managed to fulfil this ambition, as I believe I accomplished a higher quality result by having this hands-on and practical approach. I want to thank René Smeets for the inspiration-sessions.

One point of improvement within this practical approach is that it would have been beneficial to start exploring the material as soon as the choice was made. Making small samples helps in getting a 'feel' for the strength, brittleness, and other properties of the material. If I would have done this before the form ideation, probably other concepts would have been designed.

Regarding the approach of the dissolution experiments, next time I would have to execute an experiment that I have no experience in, I should ask an experienced person for help. My contact at the faculty of chemical engineering did not mention information on the experiment itself, only on the possible outcomes. Next time, I should ask if there are guidelines before executing the experiment myself. I want to thank Bijoy Bera for helping me on my way.

However, this went well when setting up the flume experiments: an experienced person helped me set up the tests, which resulted in a successful experiment. I want to thank Bas Hofland for his time and enthusiasm in guiding me in the technical part, and I want to thank Chantal Willems for her reliable guidance in the practical part. I am happy that I managed to fulfil this ambition of wanting to learn how to set up and execute performance tests.



3. HOW DID I DECIDE WHAT WAS RIGHT?

This question is much more fundamental, being about principles and values and the reasoning behind choices. Am I doing things for the right reason?

An exemplary situation is when the idea for the flume experiments was tossed, I was not hesitant to take this opportunity to learn how to do such a test. However, I was a bit naive in the expected workload: making the test set-up took around three full weeks (just as the lab technician told me). This caused my other planned work to become behind on schedule, while this test setup had priority. I decided on priorities based on my belief: collecting data is needed to prove the functionality of the product. Postponing other work was the right thing to do.



Another example that pops into my mind is about the weeks I had to quarantine. During that time I felt miserable and could not focus on my studies. I felt bad about the small amount of progress I made, but upon reflection, I found that I value mental stability more than academic results. This also shows in the way I managed the project: evening hours and weekends should be available for yourself and academic results should not be put above that.

One ambition I had, revolved around making an ecologically relevant impact. Even though this is my vision, this is difficult to use as a reasoning tool during the project. In my opinion, sharing as much information with others helps in spreading awareness on the issue and in connecting with useful individuals. Looking back on the project as is, I contributed to the possibility of making an impact. I want to thank Renate Olie for the feedback from De Rijke Noordzee.

Most of the project played on a detail level (what should the design look like, what material to use), while sometimes I also zoomed out and looked at the bigger picture. How to make this successful for all types of reefs? My ambition of making an impact guided me in deciding to test different types of sediment in the flume test, so the needed information is there when wanting to use the tile on different species. I want to thank Jeroen van Erp for his bird-eye view of the project and for guiding me on what is needed to make this project successful in a larger picture.

On the topic of making an impact, I want to thank Michaël Laterveer for trusting me with this project and guiding me on the biological questions. His perseverance in successfully restoring reefs was highly motivating.

I want to thank Maurits Willemen for his unstoppable enthusiasm and great advice on all kinds of topics. I valued your time and input during the Friday-afternoon meetings.

GLOSSARY

Abiotic: “Non-living materials and conditions within a given ecosystem, including rock, or aqueous substrate, weather and climate, topographic relief and aspect, the nutrient regime, hydrological regime, and salinity regime”. (SER, 2004)

Baseline: “An ecosystem prior to degradation” (as used by the Convention on Biological Diversity).

Bed shear stress [bodemschuifspanning]: Tangential forces per unit bed area exerted by the flow on the river bed, as a measure of flow strength.

Benthos: Organisms living in or on the sediment on the seafloor.

Benthic invertebrates: Organisms that live on the bottom of a water body (or in the sediment) and have no backbone.

Biodiversity: The variability among living organisms from all species.

Biodegradability: A material can be regarded as biodegradable when it can be broken down by living organisms into biomass, water and natural occurring gasses (such as methane and carbon dioxide).

Biofilm formation: A process whereby microorganisms irreversibly attach to and grow on a surface.

Biotic: “Living plants, animals, and microorganisms within a given ecosystem”. (SER, 2004)

Bivalves: “Aquatic molluscs which have their body enclosed within two hinged shells, such as oysters, clams, mussels, and scallops”. (Fitzsimons, 2019)

Bottom trawling: A fishing practice that herds and captures a target species, like ground fish or crabs, by towing a net along the ocean floor.

Conspecific: A member of the same species.

Cultch: “Any substrate to which a juvenile shellfish is attached or may attach”. (Fitzsimons, 2019)

Ecological recovery: The achieved outcome of ecological restoration.

Ecological restoration: “The process of initiating, assisting, or accelerating the recovery of an ecosystem that has been degraded, damaged, or destroyed. Aims to move a degraded ecosystem into a trajectory of recovery with respect to its health, integrity, and sustainability”. (SER, 2004; Gann et al., 2019)

Ecosystem: Assemblage of biotic and abiotic components in which the components interact to form complex food webs, nutrient cycles, and energy flows.

Ecosystem engineers: Reef-forming shellfish that affect their physical environment in such a way that it improves habitat for this species and other species.

Ecosystem functions: “The dynamic attributes of ecosystems, including interactions among organisms and interactions between organisms and their environment”. (SER, 2004)

Epibenthos/epifauna: Organisms that live on hard substrates above the sediment.

Filter feeders: A sub-group of suspension feeding animals that feed by straining suspended matter and food particles from water, typically by passing water over a filtering structure.

Gregarious animals: Animals living in flocks or loosely organized communities. For the *Ostrea Edulis*, gregariousness means that newly-arriving larvae settle close to existing individual members of their species.

Habitat: “The dwelling place of an organism or community that provides the requisite conditions for its life processes”. (SER, 2004)

Infauna: Organisms that live in the sediment.

Intrinsic value (of ecosystems and biodiversity): “The value that an entity has in itself, for what it is, or as an end. The contrasting type of value is instrumental value. Instrumental value is the value that something has as a means to a desired or valued end”. (Gann et al., 2019)

Keystone species: An organism that defines an entire ecosystem and is essential for its existence.

Molluscs: Organisms that have soft bodies, typically with a ‘head’ and a ‘foot’ region. Often their bodies are covered by a hard exoskeleton.

Protandrous: A hermaphrodite organism having the male reproductive organs come to maturity before the female.

Reef: ‘Oyster reef’ is a term used throughout this report and refers to structural features in coastal waters created through the aggregation and accumulation of oysters. These structural features can vary in height depending on the depth of water and other physical attributes. Where the aggregations form a single layer and do not clump on top of each other they are often called ‘beds’ (but are considered an ‘oyster reef’ for the purposes of this document).

Reference ecosystem: A model of an undisturbed ecosystem. Useful for planning and evaluating an ecological restoration project.

Resilience: The ability of an ecosystem to regain structural and functional attributes that have suffered harm from stress or disturbance.

Restoration: The process of establishing or reestablishing a habitat that in time can come to closely resemble a natural former condition in terms of structure and function.

Sand ripple: Small bedform of a few centimeters high, with a long crest perpendicular to the flow.

Scour [Ontgronding, Uitschuring]: Local removal of sediment from the stream bed by flowing water.

Sessile: Organism that is fixed in one place (immobile); it lacks a means of self-locomotion.

Spat: “Common term for post-larval juvenile oysters or mussels, after they have attached to hard substrate”. (Fitzsimons, 2019)

Substrate: Material (e.g. sand, rock, shell, debris, or other medium) where organisms grow on.

Subtidal: Area where the seabed is below the lowest tide; permanently under water.

Suspension feeders: Animals that eat material, such as plankton, that is suspended in the water around them.

BIBLIOGRAPHY

1. (MEA), M.E.A., Ecosystems and human well-being: synthesis., I. Press, Editor. 2005: Washington, D.C. Protected Area: Should there be widespread restorative management? *Biological Conservation*, 2018. 221: p. 293-311.
2. Airoidi, L., et al., Loss, Status and Trends for Coastal Marine Habitats of Europe. *An Annual Review*, 2007. 45: p. 345-405.
3. Norse, E.A., L.B. Crowder, and M.E. Soule, *Marine Conservation Biology: the Science of Maintaining the Sea's Biodiversity*. 2005, Island Press: Washington.
4. Beck, M.W., et al., Oyster Reefs at Risk and Recommendations for Conservation, Restoration, and Management. *BioScience*, 2011. 61(2): p. 107-116.
5. Coen, L., et al., Ecosystem services related to oyster restoration. *Marine Ecology Progress Series*, 2007. 341: p. 303-307.
6. van Duren, L., et al., Rijke riffen in de Noordzee: verkenning naar het stimuleren van natuurlijke riffen en gebruik van kunstmatig hard substraat. 2016.
7. Korringa, P., Recent advances in oyster biology. *Q Rev Biol*, 1952. 27(4): p. 539-65; concl.
8. OSPAR, Background document for *Ostrea edulis* and *Ostrea edulis* beds. OSPAR Publication, 2009. 428.
9. Smaal, A.C., et al., Feasibility of Flat Oyster (*Ostrea edulis* L.) restoration in the Dutch part of the North Sea. 2015.
10. Dijkema, R., Molluscan Fisheries and Culture in the Netherlands., in *The History, Present Condition and Future of the Molluscan Fisheries of North and Central America and Europe*, vol. 3: Europe. 1997b, US Department of Commerce.
11. Waardenburg, B., Options for biodiversity enhancement in offshore wind farms. 2020, Stichting Natuur & Milieu, Stichting De Noordzee.
12. Baggett, L.P., et al., Guidelines for evaluating performance of oyster habitat restoration. *Restoration Ecology*, 2015. 23(6): p. 737-745.
13. Fariñas-Franco, J.M., et al., Missing native oyster (*Ostrea edulis* L.) beds in a European Marine Protected Area: Should there be widespread restorative management? *Biological Conservation*, 2018. 221: p. 293-311.
14. Pogoda, B., et al., The Native Oyster Restoration Alliance (NORA) and the Berlin Oyster Recommendation: bringing back a key ecosystem engineer by developing and supporting best practice in Europe. *Aquat. Living Resour.*, 2019. 32: p. 13.
15. zu Ermgassen, P., et al., Forty questions of importance to the policy and practice of native oyster reef restoration in Europe. *Aquatic Conservation Marine and Freshwater Ecosystems*, 2020. 30: p. 2038-2049.
16. Kamermans, P., et al., Offshore Wind Farms as Potential Locations for Flat Oyster (*Ostrea edulis*) Restoration in the Dutch North Sea. *Sustainability*, 2018. 10(11).
17. Vrooman, J., et al., North Sea wind farms: ecological risks and opportunities. 2019, North Sea Foundation: Utrecht, the Netherlands.
18. SER, *The SER International Primer on Ecological Restoration*, S.f.E.R.I.S.a.P.W.G. (SER), Editor. 2004, Society for Ecological Restoration.
19. Delft, T., Impact voor een betere samenleving: TU Delft Strategisch Kader 2018-2024. 2018.
20. DesignCouncil, *Eleven lessons: managing design in eleven global companies*. 2007: U.K.
21. Jackson, A. and C. Wilding, *Ostrea edulis*. Native oyster. 2009, Marine Life Information Network: Biology and Sensitivity Key Information Sub-programme [Online].
22. Reeves, S.E., et al., Facilitating Better Outcomes: How Positive Species Interactions Can Improve Oyster Reef Restoration. *Frontiers in Marine Science*, 2020. 7(656).
23. Keith, H., et al., A conceptual framework and practical structure for implementing ecosystem condition accounts. *One Ecosystem*, 2020. 5: p. e58216.
24. Hobbs, R.J., *Setting Effective and Realistic Restoration Goals: Key Directions for Research*.

- Restoration Ecology, 2007. 15(2): p. 354-357.
25. Smaal A, et al., Platte oesters in offshore windparken (POP). Wageningen Marine Research., 2017. Report C035/17.
 26. Booth, D.M. and K. Heck, Effects of the American oyster *Crassostrea Virginica* on growth rates of the seagrass *Halodule wrightii*. Marine Ecology-progress Series - MAR ECOL-PROGR SER, 2009. 389: p. 117-126.
 27. Olsen, O., The Piscatorial Atlas of the North Sea, English and St. George's Channels: Illustrating the Fishing Ports, Boats, Gear, Species of Fish (how, where and when Caught), and Other Information Concerning Fish and Fisheries. 1883: OT Olsen.
 28. Lenihan, H.S., Physical-biological coupling on oyster reefs: how habitat structure influences individual performance. Ecological Monographs, 1999. 69(3): p. 251-275.
 29. Fitzsimons, J., et al., Restoration Guidelines for Shellfish Reefs. The Nature Conservancy. 2019, Arlington VA, USA.
 30. Grabowski, J.H. and C.H. Peterson, Restoring Oyster Reefs to Recover Ecosystem Services, in Theoretical Ecology Series, K. Cuddington, et al., Editors. 2007, Academic Press. p. 281-298.
 31. Gann, G.D., et al., International principles and standards for the practice of ecological restoration. Second edition. Restoration Ecology, 2019. 27(S1): p. S1-S46.
 32. Have van der, T., Voortoets platte oester-pilot Borkumse Stenen, Noordzee, in Toetsing in het kader van de Wet natuurbescherming, B. Waardenburg, Editor. 2018: Culemborg, Netherlands.
 33. Rijksoverheid. Hoeveel ruimte gebruikt wind op zee? 2021; Available from: <https://windopzee.nl/onderwerpen/wind-zee/hoeveel-ruimte/#:~:text=Dat%20komt%20neer%20op%200,om%20ongeveer%2095,4%20vierkante%20kilometer.>
 34. Workgroup, M.I.O.R., Harris Creek Oyster Restoration Tributary Plan, in Chesapeake Bay Program, W.o.t.S.F.G.I. Team, Editor. 2013: Annapolis, Maryland.
 35. Child, A.R. and I. Laing, Comparative low temperature tolerance of small juvenile European, *Ostrea edulis* L., and Pacific oysters, *Crassostrea gigas* Thunberg. Aquaculture Research, 2008. 29: p. 103-113.
 36. Icona, Noordzeeatlas voor het Nederlandse beleid en beheer. 2004: ICONA Den Haag / Stadsuitgeverij Amsterdam.
 37. Rus-van der Velde, M. and M. van Velzen-de Boer, De Rijke Noordzee - Juridische verkenning natuurontwikkeling binnen windmolenparken op zee, V.B. Keulen, Editor. 2020: Utrecht.
 38. Didderen, K., et al., Shellfish bed restoration pilots Voordelta, Netherlands. 2018.
 39. Didderen, K., et al., Pilot to actively restore native oyster reefs in the North Sea: comprehensive report to share lessons learned in 2018. 2019, Bureau Waardenburg.
 40. Sas, H., et al., Recommendations for flat oyster restoration in the North Sea. 2019.
 41. Molenaar, J., Stakeholderanalyse platte oester herstelprojecten. 2020, Hogeschool Van Hall Larenstein: Leeuwarden.
 42. Lengkeek, W., et al., Eco-friendly design of scour protection: potential enhancement of ecological functioning in offshore wind farms : Towards an implementation guide and experimental set-up. 2017, Bureau Waardenburg: Culemborg.
 43. Cole, H.A. and E.W.K. Jones, Some Observations and Experiments on the Settling Behaviour of Larvae of *Ostrea edulis*. ICES Journal of Marine Science, 1939. 14(1): p. 86-105.
 44. Laing, I., P. Walker, and F.J. Areal. A feasibility study of native oyster (*Ostrea edulis*) stock regeneration in the United Kingdom. CARD Project FC1016Native Oyster Stock Regeneration -A Review of Biological, Technical and Economic Feasibility. 2005.
 45. Smyth, D., et al., Settlement of *Ostrea edulis* is determined by the availability of hard substrata rather than by its nature: Implications for stock recovery and restoration of the European oyster. Aquatic Conserv: Mar Freshw Ecosyst., 2018. 28(3): p. 662-671.
 46. Soniat, T., R. C. Broadhurst, and E.L. Haywood., Alternatives to clamshell as cultch for oysters, and the use of gypsum for the production of cultchless oysters. J. Shellfish Res., 1991. 10.
 47. Coombes, M.A., et al., Getting into the groove:

- Opportunities to enhance the ecological value of hard coastal infrastructure using fine-scale surface textures. *Ecological Engineering*, 2015. 77: p. 314-323.
48. Hanlon, N., L.B. Firth, and A.M. Knights, Time-dependent effects of orientation, heterogeneity and composition determines benthic biological community recruitment patterns on subtidal artificial structures. *Ecological Engineering*, 2018. 122: p. 219-228.
 49. Potet, M., et al., Which concrete substrate suits you? *Ostrea edulis* larval preferences and implications for shellfish restoration in Europe. *Ecological Engineering*, 2021. 162: p. 106159.
 50. Chamberland, V.F., et al., New Seeding Approach Reduces Costs and Time to Outplant Sexually Propagated Corals for Reef Restoration. *Scientific Reports*, 2017. 7(1): p. 18076.
 51. Hamer, J.P., G. Walker, and J.W. Latchford, Settlement of *Pomatoceros lamarkii* (Serpulidae) larvae on biofilmed surfaces and the effect of aerial drying. *Journal of Experimental Marine Biology and Ecology*, 2001. 260(1): p. 113-131.
 52. Dobretsov, S., R.M.M. Abed, and M. Teplitski, Mini-review: Inhibition of biofouling by marine microorganisms. *Biofouling*, 2013. 29(4): p. 423-441.
 53. Rodriguez-Perez, A., et al., Conservation and restoration of a keystone species: Understanding the settlement preferences of the European oyster (*Ostrea edulis*). *Marine Pollution Bulletin*, 2019. 138: p. 312-321.
 54. Wang, Q., et al., Effects of different substrates on settlement and growth of pearl oyster (*Pinctada maxima*) larvae in hatcheries. *Aquacultural Engineering*, 2017. 77: p. 15-19.
 55. Ells, V., et al., A true test of colour effects on marine invertebrate larval settlement. *Journal of Experimental Marine Biology and Ecology*, 2016. 483: p. 156-161.
 56. McAfee, D., et al., Structural traits dictate abiotic stress amelioration by intertidal oysters. *Functional Ecology*, 2018. 32(12): p. 2666-2677.
 57. Lagarde, F., et al., Recruitment of the Pacific oyster *Crassostrea gigas* in a shellfish-exploited Mediterranean lagoon: discovery, driving factors and a favorable environmental window. *Marine Ecology Progress Series*, 2017. 578: p. 1-17.
 58. Colden AM, Latour RJ, and L. RN, Reef height drives threshold dynamics of restored oyster reefs. *Mar Ecol Prog Ser*, 2017(582): p. 1-13.
 59. Sawusdee, A., et al., Improvements in the physiological performance of European flat oysters *Ostrea edulis* (Linnaeus, 1758) cultured on elevated reef structures: Implications for oyster restoration. *Aquaculture*, 2015. 444: p. 41-48.
 60. Guy, C., D. Smyth, and D. Roberts, The importance of population density and inter-individual distance in conserving the European oyster *Ostrea edulis*. *Journal of the Marine Biological Association of the United Kingdom*, 2019. 99(3): p. 587-593.
 61. Hatcher, P.E. and N. Battey, *Biological Diversity: Exploiters and Exploited*, ed. Wiley-Blackwell. 2011.
 62. Kirkegaard, J., et al., *Users Guide to Physical Modelling and Experimentation*. 2011, Department of Geography, University of Hull, : Hull, UK.
 63. HSE, *Manual handling at work: A brief guide*, H.a.S. Executive, Editor. 2020.
 64. Kals, H.J.J., *Industrial Production: The Manufacture of Mechanical Products*. 2019: Boom uitgevers.
 65. Formula, S.-G., *FINE CASTING - Construction Materials, Fibrous and Decorative Plaster*. 2017.
 66. Porter, E.T., L.P. Sanford, and S.E. Suttles, Gypsum dissolution is not a universal integrator of 'water motion'. *Limnology and Oceanography*, 2000. 45(1): p. 145-158.
 67. Aljubouri, Z.A. and H.A. Al-Kawaz, Dissolution Rate of Gypsum Under Different Environments. *Iraqi Journal of Earth Sciences*, 2007. Vol. 7(No. 2): p. pp.11-18.
 68. Howerton, R. and C. Boyd, Measurement of Water Circulation in Ponds with Gypsum Blocks. *Aquacultural Engineering*, 1992. 11: p. 141-155.
 69. Klimchouk, A., The dissolution and conversion of gypsum and anhydrite. *Int.] Speleol.*, 1996. 25.
 70. Lenntech. *Composition of sea water*. 2021.
 71. Thompson, L. and E. Glenn, *Plaster standards to measure water motion*. Environmental Research Laboratory, 1994.

72. ICES, Dataset on Ocean Hydrography, T.I.C.f.t.E.o.t. Sea, Editor. 2013: Copenhagen, Denmark.
73. Keaton, J.R., S.K. Mishra, and P.E. Clopper, Scour at Bridge Foundations on Rock. 2012: Transportation Research Board.
74. Andrade, J. and D. Dal Molin, APPLICATION OF RELIABILITY THEORY IN SERVICE LIFE PREDICTION OF INITIATION TIME, in Challenges of Concrete Construction: Volume 3, Repair, Rejuvenation and Enhancement of Concrete. p. 423-432.
75. Moses, C. and D.A. Robinson, Intertidal cohesive foreshores: Erosion rates and processes illustrated by a shore platform at Warden Point, Kent, UK. *Marine Geology*, 2021. 442: p. 106658.
76. Industries, E., Safety data Calcium sulfate 2013.
77. La Russa, M.F. and S.A. Ruffolo, Mortars and plasters - How to characterize mortar and plaster degradation. *Archaeological and Anthropological Sciences*, 2021. 13(10): p. 165.
78. Calcinai, B., et al., Excavating rates and boring pattern of *Cliona albimarginata* (Porifera: Clionidae) indifferent substrata. *Porifera Research: Biodiversity, Innovation and Sustainability*, 2007.
79. Manning, T.J., et al., The Use of Microbial Coatings, Nutrients and Chemical Defense Systems in Oyster Restoration. *Marine Technology Society Journal*, 2019. 53(4): p. 39-54.
80. Argyris, C. and D. Schön, *Theory in Practice: Increasing Professional Effectiveness*. 1974, Jossey-Bass: San Francisco.
81. Lok, A. and S. Acarli, Preliminary study of settlement of flat oyster spat (*Ostrea edulis* L.) on oyster and mussel shell collectors. *Israeli Journal of Aquaculture - Bamidgeh*, 2006. 58(2): p. 105-115.
82. Goelz, T., B. Vogt, and T. Hartley, Alternative Substrates Used for Oyster Reef Restoration: A Review. *Journal of Shellfish Research*, 2020. 39(1): p. 1-12, 12.
83. Colsoul, B., et al., Addressing critical limitations of oyster (*Ostrea edulis*) restoration: Identification of nature-based substrates for hatchery production and recruitment in the field. *Aquatic Conserv: Mar Freshw Ecosyst.*, 2020. 30(11): p. 2101-2115.
84. La Peyre, M., et al., Oyster reef restoration in the northern Gulf of Mexico: extent, methods and outcomes. *Ocean Coastal Management*, 2014. 89: p. 20-28.
85. Graham, P.M., T.A. Palmer, and J. Beseres Pollack, Oyster reef restoration: substrate suitability may depend on specific restoration goals. *Restoration Ecology*, 2017. 25(3): p. 459-470.
86. Soniat, T.m. and G.m. Burton, A comparison of the effectiveness of sandstone and limestone as cultch for oysters. *Journal of Shellfish Research*, 2005. 24(2): p. 483-485, 3.
87. George, L.M., et al., Oyster reef restoration: effect of alternative substrates on oyster recruitment and nekton habitat use. *Journal of Coastal Conservation*, 2015. 19(1): p. 13-22.
88. Dunn, R.P., D.B. Eggleston, and N. Lindquist, Effects of Substrate Type on Demographic Rates of Eastern Oyster (*Crassostrea virginica*). *Journal of Shellfish Research*, 2014. 33(1): p. 177-185, 9.
89. Newtab-22, Sea Stone is a concrete-like material made from shells, Dezeen, Editor. 2020. p. <https://www.dezeen.com/2020/08/28/sea-stone-newtab-22-design-shells-materials/>.
90. Gwilen, Sedimentary material. p. <https://www.gwilen.com/en/le-materiau/>.
91. BESE, Biodegradable Ecosystem Engineering Elements are 3D structures made out of potato starch. p. <https://www.bese-products.com/biodegradable-products/bese-elements/>.
92. Roest, L.W.M., Predicting currents at the Gemini wind farm: Analysis of Triaxys ADCP-data, V. Oord, Editor. 2015, Delft University of Technology: Rotterdam.
93. Martini, M., et al., Accessibility assessment for operation and maintenance of offshore wind farms in the North Sea. *Wind Energ.*, 2017. 20(4): p. 637-656.
94. Winter de, R., et al., The effect of climate change on extreme waves in front of the Dutch coast. *Ocean Dynamics*, 2012. 62(8): p. 1139-1152.
95. Paulsen, B.T., et al., Probability of wave slamming and the magnitude of slamming loads on offshore wind turbine foundations. *Coastal Engineering*, 2019. 143: p. 76-95.
96. Claessens, C., Episodic density-induced current velocities at the Gemini offshore wind park. 2016,

97. Schiereck, G.J., Introduction to bed, bank, shore protection. Engineering the interface of soil and water. 2016, Delft: Delft Academic Press.
98. Pirlet, H., et al., The Mermaid project - Innovative Multi-Purpose Offshore Platforms. 2014, Flanders Marine Institute (VLIZ): Ostend.
99. Bos, O.G. and A.J. Pajmans, Verkenning natuurwaarden Borkumse Stenen: project Aanvullende Beschermde Gebieden. 2012, IMARES (Rapport / IMARES Wageningen UR C137/12).
100. Witbaard, R., O.G. Bos, and H.J. Lindeboom, Basisinformatie over de Borkumer Stenen, Bruine Bank en Gasfonteinen, potentieel te beschermen gebieden op het NCP. 2008, IMARES Wageningen UR.
101. BSH, Der küstennahe Gezeitenstrom in der Deutschen Bucht. 2017b.
102. NOAH. Work Areas - NOAH A. Available from: https://www.noah-project.de/work_areas/index.php.en.
103. Larsen, S., et al., Wind and wave loads to Borkum Riffgrund wind farm. 2006.
104. James, A.N. and A.R. Lupton, Gypsum and Anhydrite in Foundation of Hydraulic Structures. Geotechnique, 1978. 28: p. 249-272.
105. Sadeghiamirshahidi, M. and S.J. Vitton, Laboratory Study of Gypsum Dissolution Rates for an Abandoned Underground Mine. Rock Mechanics and Rock Engineering, 2019. 52(7): p. 2053-2066.
106. Sabine, A., et al., Environmental conditions influence tissue regeneration rates in scleractinian corals. Marine Pollution Bulletin, 2015. 95.

DESIGN
FOR OUR
future

IDE Master Graduation

Project team, Procedural checks and personal Project brief

This document contains the agreements made between student and supervisory team about the student's IDE Master Graduation Project. This document can also include the involvement of an external organisation, however, it does not cover any legal employment relationship that the student and the client (might) agree upon. Next to that, this document facilitates the required procedural checks. In this document:

- The student defines the team, what he/she is going to do/deliver and how that will come about.
- SSC E&SA (Shared Service Center, Education & Student Affairs) reports on the student's registration and study progress.
- IDE's Board of Examiners confirms if the student is allowed to start the Graduation Project.

! USE ADOBE ACROBAT READER TO OPEN, EDIT AND SAVE THIS DOCUMENT

Download again and reopen in case you tried other software, such as Preview (Mac) or a webbrowser.

STUDENT DATA & MASTER PROGRAMME

Save this form according the format "IDE Master Graduation Project Brief_familyname_firstname_studentnumber_dd-mm-yyyy".

Complete all blue parts of the form and include the approved Project Brief in your Graduation Report as Appendix 1 !



family name Raspoort
 initials A. J. given name Anne
 student number 4459997
 street & no. _____
 zipcode & city _____
 country Netherlands
 phone _____
 email _____

Your master programme (only select the options that apply to you):

IDE master(s): IPD Dfl SPD

2nd non-IDE master: _____

individual programme: - - (give date of approval)

honours programme: Honours Programme Master

specialisation / annotation: Medisign

Tech. in Sustainable Design

Entrepreneurship

SUPERVISORY TEAM **

Fill in the required data for the supervisory team members. Please check the instructions on the right !

** chair Jeroen van Erp dept. / section: Human-Centered Desig
 ** mentor Maurits Willemen dept. / section: Sustainable Design Eng
 2nd mentor Michaël Laterveer
 organisation: Blue Linked
 city: Hazerswoude-dorp country: Netherlands

comments
(optional)

⋮

Chair should request the IDE Board of Examiners for approval of a non-IDE mentor, including a motivation letter and c.v..



Second mentor only applies in case the assignment is hosted by an external organisation.



Ensure a heterogeneous team. In case you wish to include two team members from the same section, please explain why.

Procedural Checks - IDE Master Graduation

APPROVAL PROJECT BRIEF

To be filled in by the chair of the supervisory team.

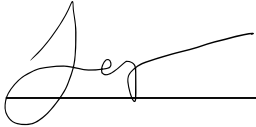
chair Jeroen van Erp date - - signature 

CHECK STUDY PROGRESS

To be filled in by the SSC E&SA (Shared Service Center, Education & Student Affairs), after approval of the project brief by the Chair. The study progress will be checked for a 2nd time just before the green light meeting.

Master electives no. of EC accumulated in total: _____ EC

YES all 1st year master courses passed

Of which, taking the conditional requirements into account, can be part of the exam programme _____ EC

NO missing 1st year master courses are:

List of electives obtained before the third semester without approval of the BoE

name _____ date - - signature _____

FORMAL APPROVAL GRADUATION PROJECT

To be filled in by the Board of Examiners of IDE TU Delft. Please check the supervisory team and study the parts of the brief marked **. Next, please assess, (dis)approve and sign this Project Brief, by using the criteria below.

- Does the project fit within the (MSc)-programme of the student (taking into account, if described, the activities done next to the obligatory MSc specific courses)?
- Is the level of the project challenging enough for a MSc IDE graduating student?
- Is the project expected to be doable within 100 working days/20 weeks ?
- Does the composition of the supervisory team comply with the regulations and fit the assignment ?

Content: APPROVED NOT APPROVED

Procedure: APPROVED NOT APPROVED

comments

name _____ date - - signature _____

The design of a reef tile for the restoration of oyster reefs in the North Sea project title

Please state the title of your graduation project (above) and the start date and end date (below). Keep the title compact and simple. Do not use abbreviations. The remainder of this document allows you to define and clarify your graduation project.

start date 13 - 09 - 2021 11 - 02 - 2022 end date

INTRODUCTION **

Please describe, the context of your project, and address the main stakeholders (interests) within this context in a concise yet complete manner. Who are involved, what do they value and how do they currently operate within the given context? What are the main opportunities and limitations you are currently aware of (cultural- and social norms, resources (time, money,...), technology, ...).

Because of human interventions in our seas, like commercial (over)fishing and the installation of offshore constructions, the presence and biodiversity of natural reefs is declining. Reefs provide a habitat for a variety of marine species and are of great value to marine ecosystems. Therefore, it is of importance to restore affected reefs.

In the North Sea, especially the presence of oyster beds has severely declined and needs to be restored; flat oyster beds are today considered to be one of the most endangered (marine) habitats in Europe. There are possibilities for restoration, which can take place around offshore wind farm sites where it is prohibited to fish from the seabed, providing desirable circumstances for the restoration of reef. Restoration can be done with different methods, but Blue Linked, a small company with experience in marine nature restoration projects, has one method which is deemed most promising.

Blue Linked has come up with the idea for 'reef tiles', where larvae of bottom-dwelling (sessile) marine organisms (such as oysters, mussels, tube worms, and anemones) can be sown in the sea with help of a small product. Once sown, the 'reef tiles' will form a natural reef (see figure 1). This idea is less labor intensive and is more suited for implementation on larger scales than existing reef restoration methods (figure 2).

This 'reef tile' has to be embodied and tested on efficacy, which will be done in this graduation project. Testing will involve research on the behavior of the 'reef tiles' on flatter bottoms, such as the gravel and sand bottoms of the North Sea, under different conditions (current, swell, etc.), and the sinking behavior of the 'reef tiles'. Tests with living oyster larvae will be executed as well. The project will finish with a set of prototypes, ready to be tested in real conditions.

There are several main stakeholders within this context. First of all, Blue Linked: this small company owned by marine biologist Michaël Laterveer is interested in marine nature restoration out of personal ambition. They have done several projects on marine nature restoration and are also involved in circular fish farming. They have connections with experts at Wageningen University and other experts in the field.

Stichting De Rijke Noordzee will finance part of this research project through Blue Linked. They work as partners of the Dutch Ministry of Agriculture, Nature, and Food Quality, which has a goal to restore biogenic reefs in the North Sea.

TU Delft will also be involved in this graduation project, as the institution wants me to showcase that I have the skills to call myself an industrial design engineer afterwards. Currently, there are few projects at IDE revolving around the restoration of nature, so this might be interesting for the TU Delft as to broaden their involvement.

Main opportunities of this project are that this product could be used on a wide range of marine animals, including endangered corals. This is a large motivator for both myself and involved stakeholders. Also, there are plenty of resources for this project to use, including knowledge from Wageningen University and funding from De Rijke Noordzee.

space available for images / figures on next page

introduction (continued): space for images

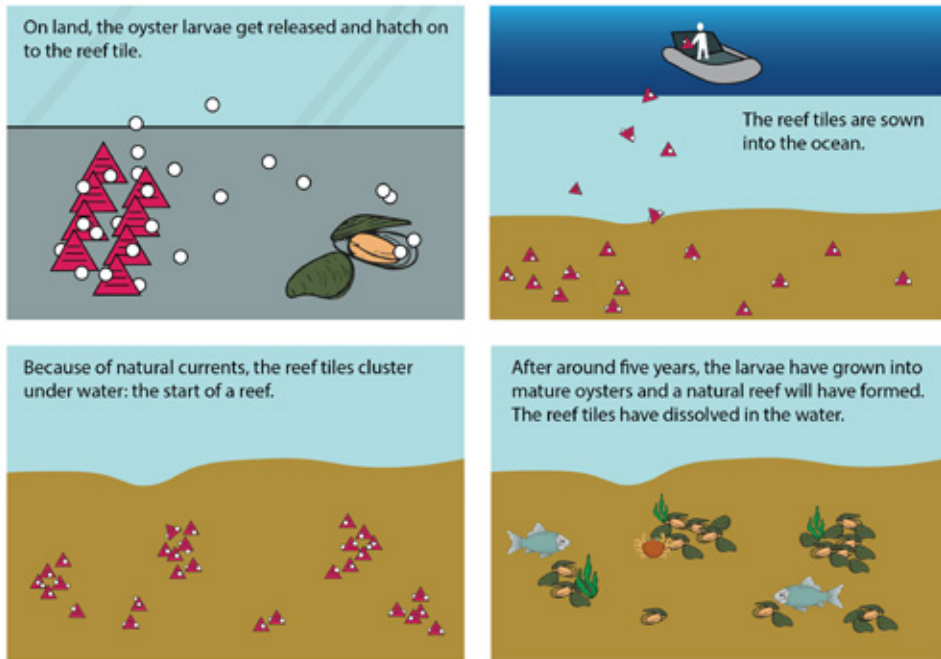

image / figure 1: Usage of the reef tile.

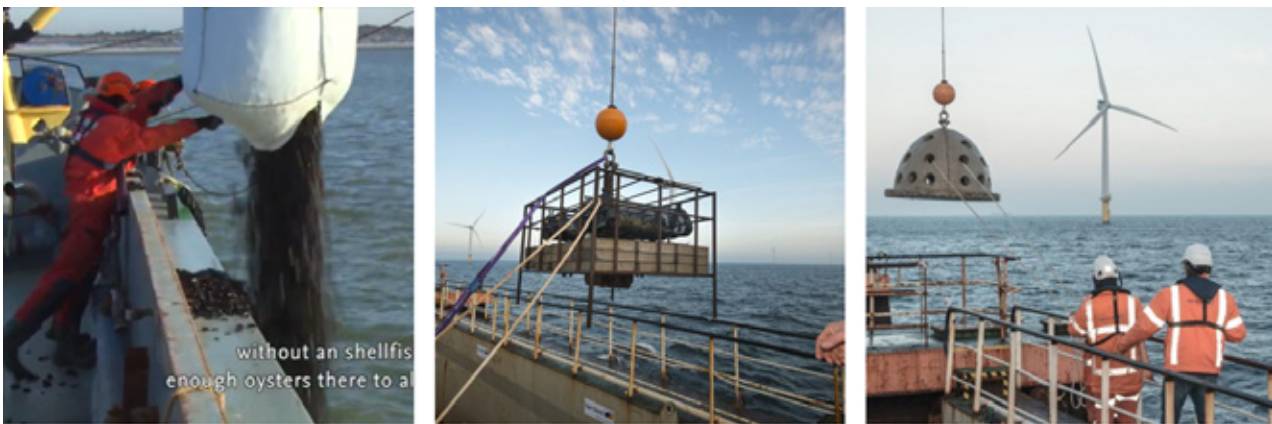

image / figure 2: Examples of current methods for oyster reef restoration; large and invasive.

PROBLEM DEFINITION **

Limit and define the scope and solution space of your project to one that is manageable within one Master Graduation Project of 30 EC (= 20 full time weeks or 100 working days) and clearly indicate what issue(s) should be addressed in this project.

Flat oyster reef ecosystems in the North Sea have declined severely in number and need to be restored. This should be done without disturbing the environment in an unnatural way.

Current reef restoration solutions include placing large structures under water for wildlife to settle on; the sandy bottom is not appealing for animals to settle on initially. However, almost the entire Dutch North Sea exists out of soft sediment, so adding large hard substrates would be unnatural. These structures are also costly to manufacture and transport, and do not guarantee that flat oysters will settle. Other solutions include setting out mature flat oysters. However, when there is no reef present it is not given that these shellfish will survive. Both solutions involve deployment of large vessels, which are costly.

The 'reef tile' builds up reef without being invasive; the small products enable reef to form naturally. The products will dissolve after the oysters have grown enough to form their own reef. Only a small vessel is needed for seeding. Setting out larvae is cheaper than setting out mature oysters, since they need less time to be taken care for in the oyster farm. The small products could be easily produced and transported. In conclusion, this idea is less labor intensive and is more suited for implementation on larger scales than existing reef restoration methods.

ASSIGNMENT **

State in 2 or 3 sentences what you are going to research, design, create and / or generate, that will solve (part of) the issue(s) pointed out in "problem definition". Then illustrate this assignment by indicating what kind of solution you expect and / or aim to deliver, for instance: a product, a product-service combination, a strategy illustrated through product or product-service combination ideas, In case of a Specialisation and/or Annotation, make sure the assignment reflects this/these.

Enable restoration of flat oyster reefs in the North Sea by designing a product that promotes attachment of larvae of flat oysters and natural reef-forming when seeded in water.

By means of this graduation project I aim to contribute to science by researching the seeding method for reef restoration. This method for restoration involves cultivating flat oyster larvae on land, letting larvae attach to a 'reef tile', transporting the 'reef tiles' to a desired location at sea, seeding the tiles in the water from a boat, and letting the tiles form a natural reef under water.

A thought-through design of the 'reef tile' is needed, in order to make this product easy to manufacture, transport, and use. The embodiment and materialization of this product will be done during this graduation project, as well as tests on underwater behavior and applicability on flat oyster larvae; its efficacy needs to be tested and proven scientifically, if this product is to be used. Finishing with a looks-like-real and works-like-real set of prototypes, the project will be ready to move on to the next phase: testing in real environments.

PLANNING AND APPROACH **

Include a Gantt Chart (replace the example below - more examples can be found in Manual 2) that shows the different phases of your project, deliverables you have in mind, meetings, and how you plan to spend your time. Please note that all activities should fit within the given net time of 30 EC = 20 full time weeks or 100 working days, and your planning should include a kick-off meeting, mid-term meeting, green light meeting and graduation ceremony. Illustrate your Gantt Chart by, for instance, explaining your approach, and please indicate periods of part-time activities and/or periods of not spending time on your graduation project, if any, for instance because of holidays or parallel activities.

start date 13 - 9 - 2021 11 - 2 - 2022 end date

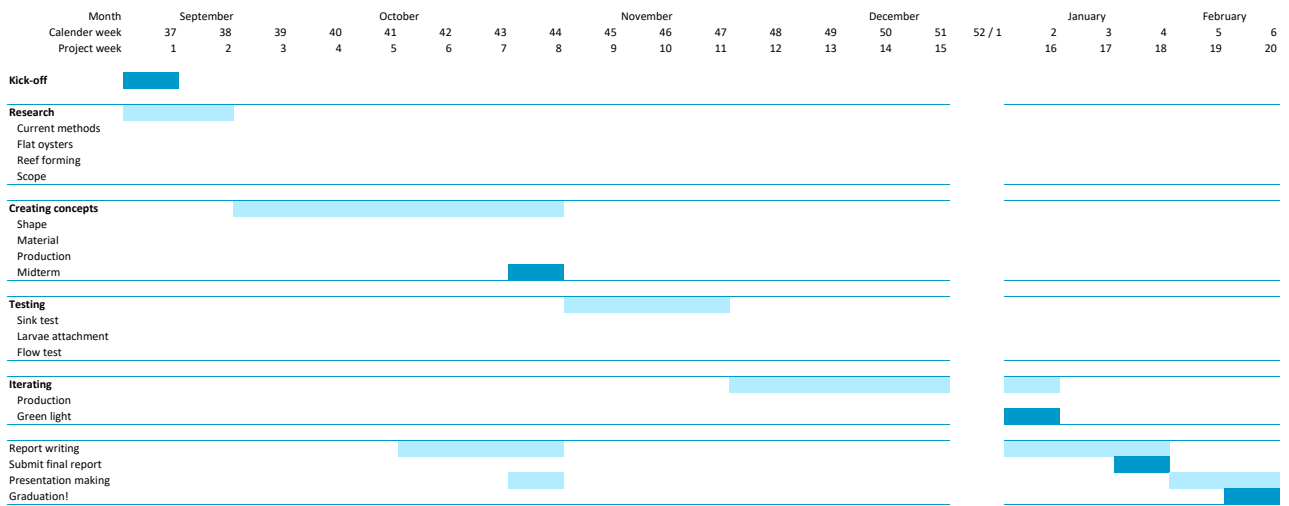

This is a project that I will work on full-time.

In the first phase, the goal is to end with a proper base of knowledge on flat oysters and reef forming so that I have the needed knowledge to start designing. In this phase I will also contact valuable experts at Wageningen University and Civil Engineering.

The second phase is about conceptualization; I want to end with four concepts that are ready to be tested. These concepts will be produced with a number of prototypes. Also, a final material will be chosen.

In the third phase, the goal is to have results on the sinking behavior, flowing behavior, and interaction behavior of the reef tile.

In the 'iteration' phase the results of the tests will be used to choose one of the concepts and iterate on that. The goal is to end with a final design, including a set of prototypes which can be used for testing in the North Sea.

Finally, I will end with a finished report and a presentation on this graduation project.

MOTIVATION AND PERSONAL AMBITIONS

Explain why you set up this project, what competences you want to prove and learn. For example: acquired competences from your MSc programme, the elective semester, extra-curricular activities (etc.) and point out the competences you have yet developed. Optionally, describe which personal learning ambitions you explicitly want to address in this project, on top of the learning objectives of the Graduation Project, such as: in depth knowledge a on specific subject, broadening your competences or experimenting with a specific tool and/or methodology, Stick to no more than five ambitions.

This project was initiated from one of my personal interests: the restoration of coral reefs. Coral experts at Wageningen University recommended Blue Linked to me, where they already had some knowledge on coral reef restoration. The idea of the 'reef tile' existed there for the restoration of coral reefs, but can also be used for any marine organism that is a larva in its juvenile stage, as is the case with flat oysters. If, during this project, the functionality of the 'reef tile' gets verified, the impact on reef restoration projects can be large. This is an enormous motivator for me.

One of the competences I want to prove involves a hands-on approach for this project. Creating, testing, and iterating would be how I envision this. In previous projects this hands-on approach was performed as a team; I would like to prove that I can do this individually as well.

An ambition that I have for this project includes learning how to set up a performance test in water, for instance a sink test or a flow test. I have never done such tests before. The flow test can be executed at the faculty of Civil Engineering, where I will try to find someone who can advise me.

Another ambition includes gaining knowledge about designing for a non-human. In this project quite some biology is involved, which is something completely new to me. I would have to gain in-depth knowledge on flat oysters and natural reef forming. I find this added value to the project very exciting.

Finally, I have the ambition for this project to make ecologically relevant impact, either by restoring large areas of reef or by coming up with a different method which could work in case the 'reef tile' does not deliver its desired functionality. I would love to deliver a product that could be tested on other sessile marine species as well.

Personal challenges include managing the boundaries of this project. I know I can be very enthusiastic about researching all of the parts of this subject, for instance experimenting with many different material compositions or other animal species, but there will not be enough time for this.

Another challenge includes the involvement of funding parties, who might have a vision already on parts of the project. This counts as well for the involvement of marine biologists, who could have a strong vision. I would have to find the balance between choosing for my own expertise and the influence of experts and stakeholders. This is both to keep the learning objectives of the graduation project in sight as well as to finish with a viable product that is ready to be produced.

In conclusion, my motivation for this project is enormous as it was born from personal interest. The goals and ambitions that I have for this project are mainly about learning new capabilities, as I am inexperienced on parts of this project. I am looking forward!

FINAL COMMENTS

In case your project brief needs final comments, please add any information you think is relevant.

Appendix 2 - Project planning

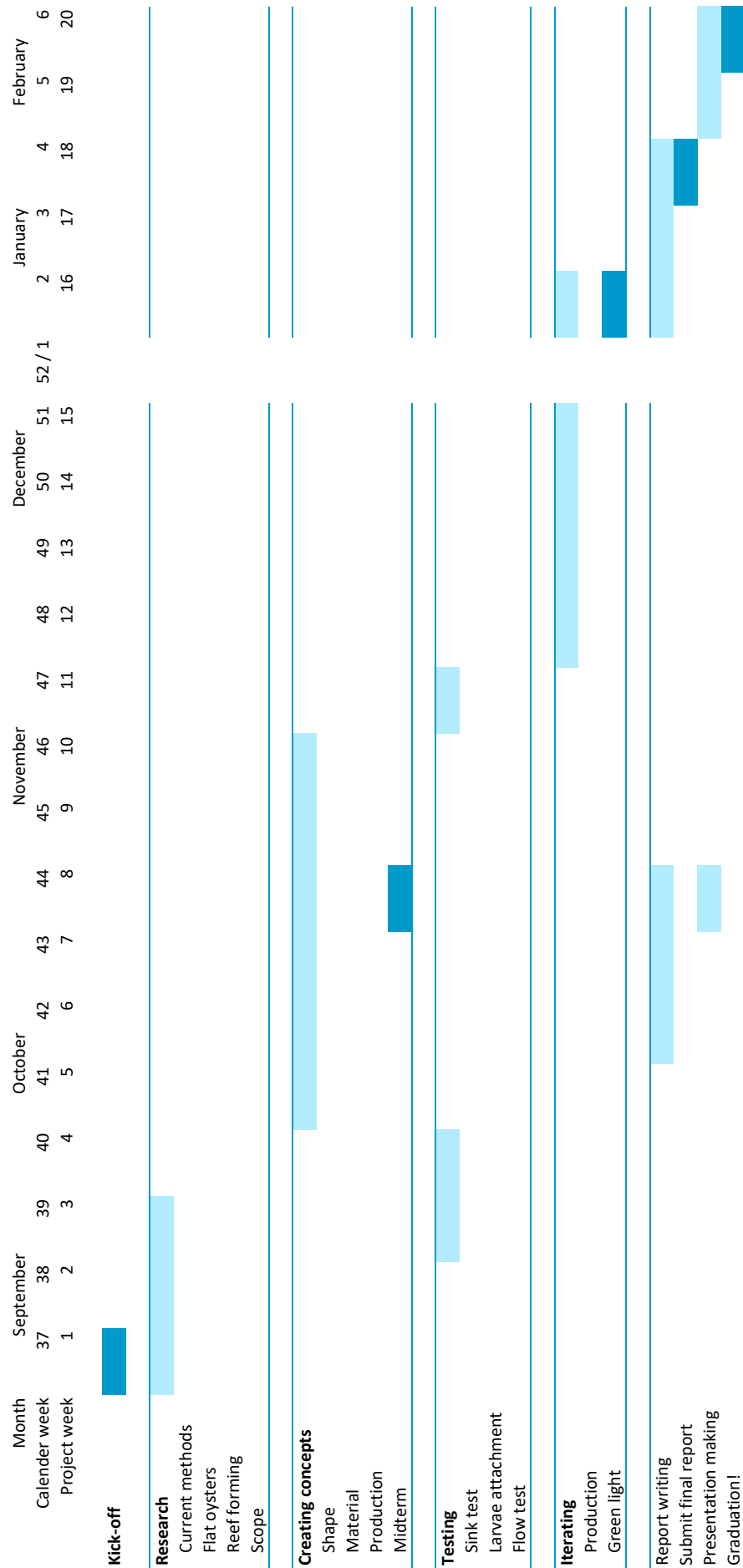

Calcareous material:



Shells:

Restoration projects have historically used recycled, fossilized, or dredged native oyster shell, as shell was recognized as the optimal hard substrate for oyster settlement and growth. Also, commercial hatcheries use small shell fragments as their prime substrate for settlement of *O. Edulis*.

Regarding the use of different types of shells, Lok and Acarli (2006) found no differences in recruitment between oyster and mussel shells [81].

As the reduction of oyster habitat is of large scale it requires a large scale restoration effort and therefore large amounts of substrate need to be available. The limited amount of available shells in most systems cannot fulfill the substantial demands of large-scale restoration projects [82].



Slaked lime (gebluste kalk):

Slaked lime is calcium based and therefore may resemble the composition of oyster shells. Materials whose composition is close to that of oyster shells are deemed suitable for oyster larvae recruitment [83]. One can produce slaked lime from magnesium–calcite hydrated lime powder.



Baked clay:

Clay has high silicate as well as high calcium and magnesium contents, again, similar to oyster shells and therefore deemed suitable [83]. Colsohl et al. showed that *O. edulis* in the field had higher settlement rates on baked clay than on slaked lime and bivalve shells [83]. Inorganic materials (lime and clay) also offer a quantitative (stable and substantial supply) and qualitative alternative without negative impacts on natural substrates. [83]



Marl:

Marl or marlstone is a sedimentary rock that can be mined in coastal areas. Marl is a CaCO_3 -based material containing clay (silt) and aragonite. It has been used frequently in restoration efforts in the United States, mainly because of its cheap availability. This material has not been tested against any other materials.

**Limestone:**

Limestone is calcareous material and therefore a suited alternative [81]. Soniat et al. appoints limestone as an economically feasible, biologically acceptable, and environmentally benign alternative to clamshell as cultch for oysters [46]. The biological acceptability of limestone for oyster recruitment has been suggested to be heavily influenced by the chemical composition of the substrate [84, 85].

Oyster larvae have a clear preference for limestone over sandstone at all salinity levels and all larval abundance levels [86]. A study by George et al. revealed that limestone performed similarly to porcelain, concrete, river rock, and oyster shell, which all performed analogous to recruitment on natural reefs [87].

**Gypsum (hydrated calcium sulfate):**

Gypsum performed better than clamshell and limestone in attracting spat [46].

In terms of solubility, Soniat et al. showed that gypsum did not dissolve in flowing seawater within two months [46].

Non-calcareous material:**Concrete:**

Concrete lacks the chemical cues that calcium-based substrates possess which have been shown to enhance biological acceptability [82].

A study by George et al. revealed that concrete performed similarly to porcelain, limestone, river rock (granite), and oyster shell, which all performed analogous to recruitment on natural reefs [87]. Graham et al. (2017) even evaluated recruitment for *Crassostrea virginica* larvae of concrete as more efficient than limestone, oyster shells, and granite [85]. Dunn et al. also supports the consideration of noncarbonate material, like concrete, as suitable reef-building substrate [88].

However, public and regulatory acceptance of concrete is low, as is for all artificial materials. This is mainly because of the potential negative effects on the environment, for instance chemical pollution [29, 83].

**Wooden material (all types):**

This natural material is not suited for oyster settlement [83].

**Granite / river rocks:**

Granite is an abundant natural stone material in the marine environment. Granite is made from quartz and feldspar and has a much coarser structure than clay and lime [83]. It is less suited for recruitment than clay, limestone, concrete, and oyster shells [85]. Granite is deemed unsuccessful in attracting oyster spat [88].

However, a study by George et al. revealed that granite performed similarly to porcelain, limestone, concrete, and oyster shell, which all performed analogous to recruitment on natural reefs [87].

**Gravel:**

Crushed roadbed and gravel are not viable alternatives [46].

**Porcelain:**

Porcelain lacks the calcium base present in other alternative substrates [82]. However, a study by George et al. revealed that porcelain performed similarly to concrete, limestone, river rock, and oyster shell, which all performed analogous to recruitment on natural reefs [87]. However, there are chemical concerns related to leaching [29].

**Sandstone:**

Sandstone lacks the calcium base present in other alternative substrates [88]. Sandstone does not appear to be a suitable alternative to limestone as a cultch for oysters [86].

**Quartzite:**

Sandstone is converted into quartzite through heating and pressure. Quarzitic sandstone, unlike sedimentary sandstone, does not have loose abrasive sand particles and, unlike gravel, has a rough texture similar to the siliceous limestone often used for recruitment. This material is used in restoration projects, but has not been tested against other materials.

**EMA:**

Electro-mineral accretion. This inorganic substrate is commonly used in coral reef restoration. Because of an oxidation reaction, beneficial minerals like CaCO_3 deposit on the iron structure, which allows the formation of complex 3D structures as settlement surfaces [83].

Appendix 4 - List of requirements and wishes

Requirements for the 'reef tile'

Material

1. The material should be naturally occurring in the Dutch North Sea;
2. The material should be biologically safe (no chemical pollution);
3. The material should promote larvae settlement;
 - 3.1 The material should be hard to allow for larvae settlement;
 - 3.2 The material should be calcareous, to promote larvae settlement;
4. The material should be denser than seawater ($>1023.6 \text{ kg/m}^3$), for the product to sink;
5. The material should withstand water temperatures between 3-30 °C;
6. The material should withstand water salinity percentages of 20-35%;

Production and design

7. The product should allow for minor changes to suit other benthic organisms as well;
8. The product should be suited to be produced in amounts of hundreds of millions;

W1. The product should be transported as efficiently as possible;

Settlement

9. The product should promote larvae settlement of at least one larva per product;
 - 9.1 The product's surface should provide spatial refuges;
 - 9.2 The product's surface should allow for biofilm formation;
 - 9.3 The product should provide shadowed or protected areas;
 - 9.4 The product should provide options for the larvae to settle vertically;
10. The product should allow people to touch/hold it without touching settled spat;

W2. The product should let larvae settle as efficiently as possible;

Performance

11. The product should be stable in flow velocities up to 0.8 m/s;
12. The product should enable oysters to have access to flowing water, as this is how they feed;
 - 12.1 The product should make sure the larvae stay above the sediment (sand of $<0,5 \text{ mm}$), so less than 50% burial;
13. The product should protect larvae against larger predators;
 - 13.1 The product's surface should provide spatial refuges;
14. The product should be large enough for a grown oyster of 5 cm long;

W3. The product should be stable in as high flow velocities as possible;

W4. The product should stay above the sediment as much as possible;

W5. The product should be able to be used on as many sediment types as possible;

W6. The products should discourage the introduction of exotics as much as possible;

W7. The product should have as little effect on the environment as possible.

End-of-life

15. The product should exist on the seabed for minimally 6 months;
16. The product should enable the water body to return to its original state within thirty years.

W8. The product exists on the seabed for as long as possible.

Appendix 5 - Motivation for choice for naturally occurring material over degradable material

Following current guidelines regarding the placement of structures in the Dutch North Sea, there are two options for the end-of-life of the product.

1. Remove from the seabed (within 30 yrs.)
 - a. Artificial materials (e.g., steel, concrete) must be removed;
 - b. Degradable material (e.g., PVA/PCL) removes itself.
2. Leave on the seabed
 - a. Naturally-occurring material (e.g., limestone).

There is no clear definition regarding 'artificial materials'. A material is artificial "when it has adverse effects on the chemical and environmental quality of the water systems". Besides, removal of the product is impossible given the size; it would be too difficult to find all products.

Therefore, two options remain: making the product out of degradable material or making it out of naturally-occurring material. Below is a trade-off table between both. The use of degradable material has more disadvantages than naturally occurring material. The two decisive arguments, however, were the needed long-term biodegradability test, which takes too much time, and the reliability of the material. This leads to a choice in favour of naturally-occurring material.

Popular term.	Higher chance of biocompatibility.
Degradable material	Can forever be used as settlement substrate for organisms.
New degradable materials need 6-month test before deployal.	Uncertainty about definition of 'natural'.
Uncertainties about lifespan of existing degradable materials.	Most of the material is difficult to shape into a product
Not necessarily also safe in environmental terms.	
Oysters loose their substrate if product degrades: less stability.	
Small range of options because requires specific lifespan: 5-30 yr.	

Appendix 6 - Bio-based material exploration

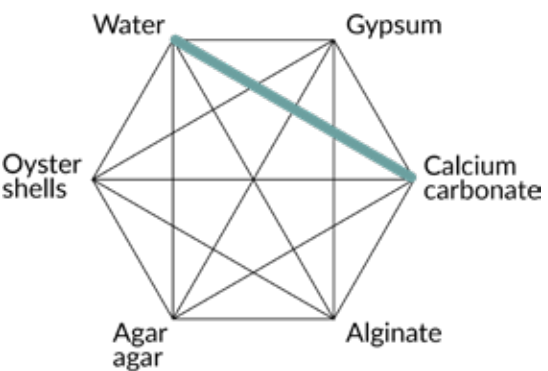
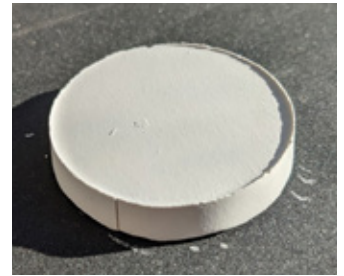
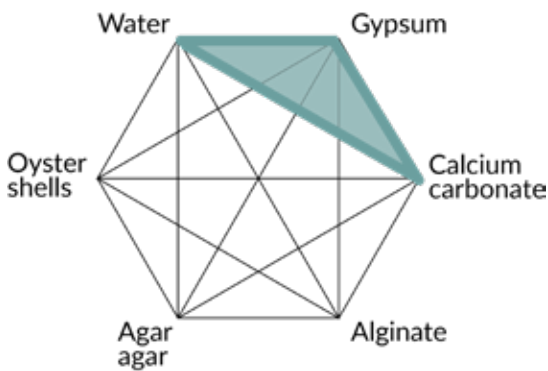
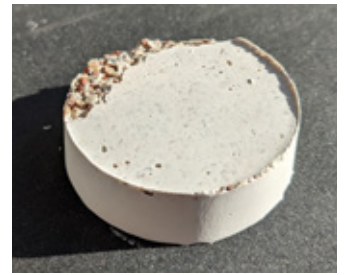
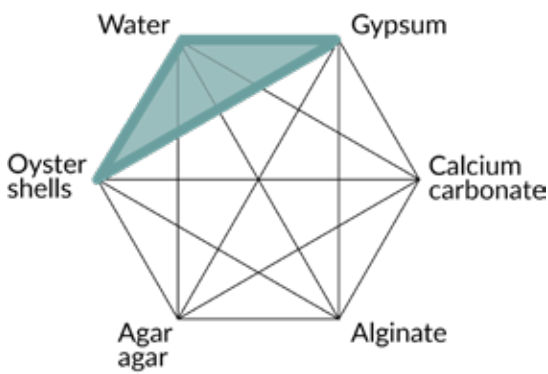
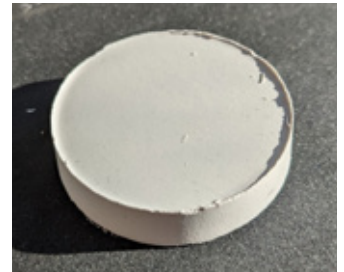
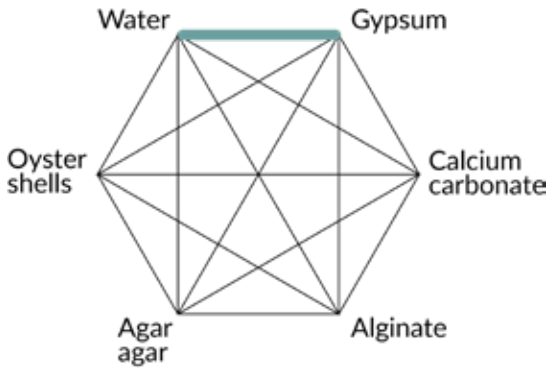

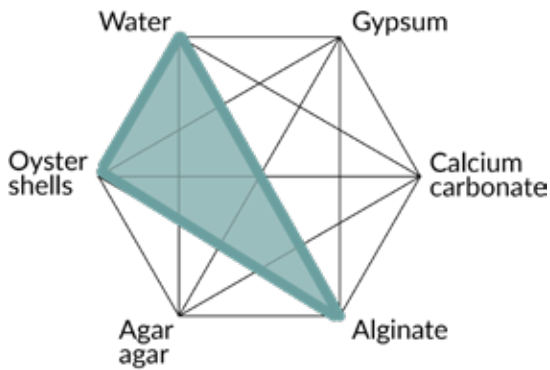
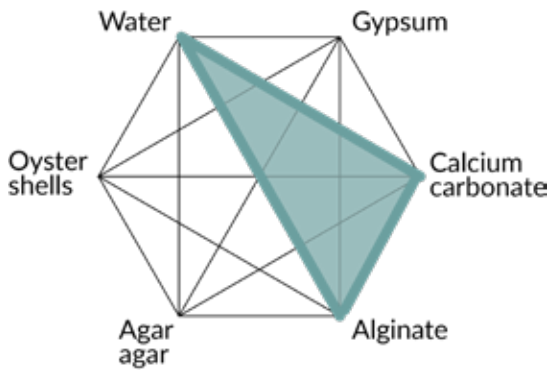
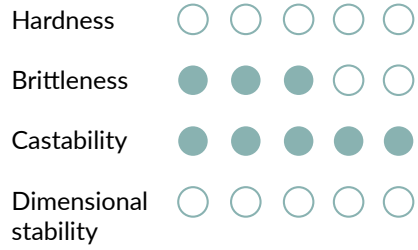
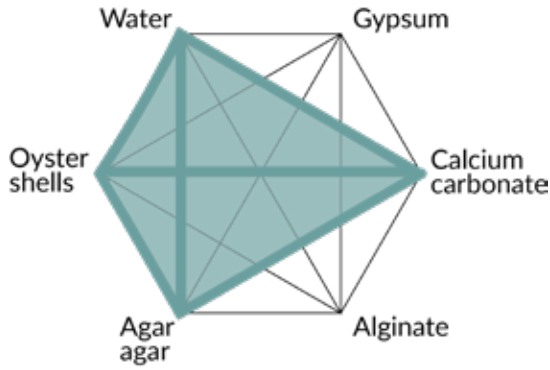
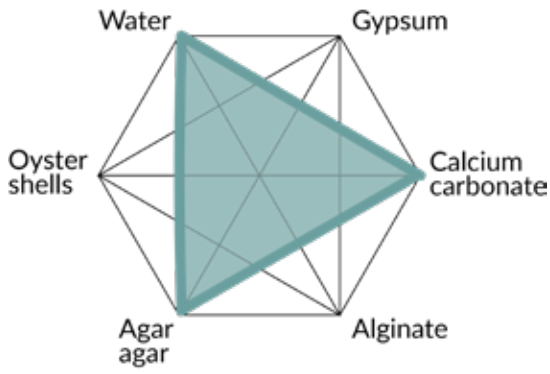

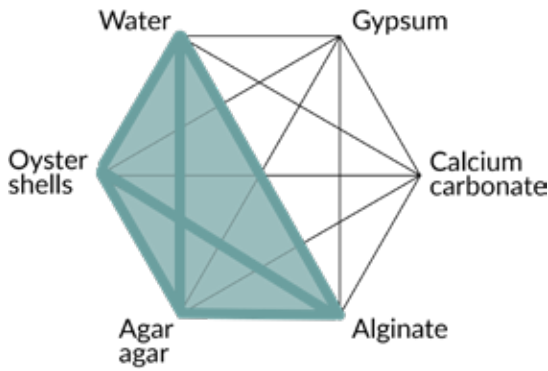

Hardness	○	○	○	○	○
Brittleness	●	●	●	○	○
Castability	●	●	●	●	●
Dimensional stability	○	○	○	○	○



Besides these easily available materials, there are also existing materials that could be suitable. 'Sea stone' is a natural castable stone made out of crushed seashells and a natural binder [89]. 'Gwilen' is a stony material made out of dredged sediment material from harbours [90]. BESE is a potato-starch based bioplastic that is degradable after five years [91]. BESE is used for a seagrass restoration product in shallow waters.

These materials are owned by other companies, which is undesirable when wanting to launch to the market quickly. Besides, the actual ingredients are unknown and are difficult to track down due to the market position of the companies. Therefore, choosing one of these materials would be too uncertain.

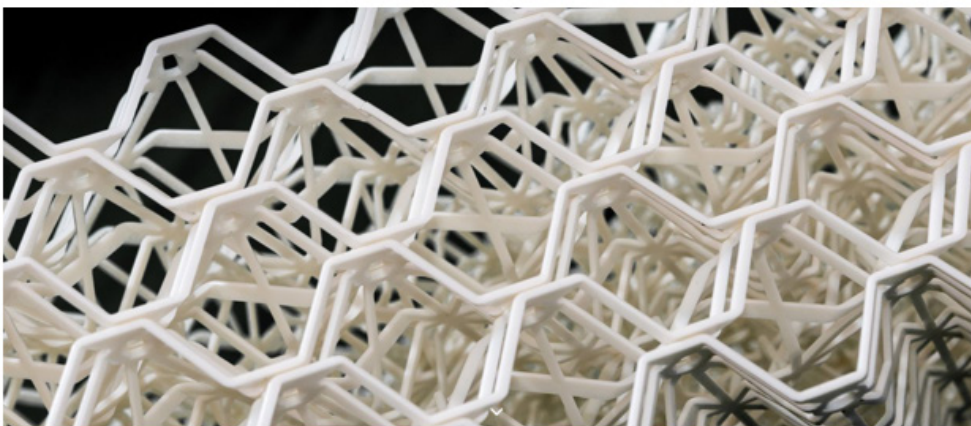

Figure: Seastone, Gwilen, and BESE material.

Appendix 7 - Flow velocities at the reference locations

The reference location for the tests is Gemini wind park (Buitengaats) and Borkumse Stenen. The fact that wind farms are free from seabed-disturbing activities in the current regulatory framework, is regarded as a major precondition for the restoration of flat oyster beds.

Gemini wind park Buitengaats:

This wind park is located in the north of the Netherlands, 55 km above Schiermonnikoog. The local water depth varies around thirty meters [92]. In this area, the sea bed motion is relatively stable in comparison to other wind park sites [9]. Sediment: mainly silty and fine sand (slibrijk en fijn zand) [9].

Tidal currents at the wind park are measured to be 0.05 m/s at the bottom layers of the sea. There is a residual current, which is measured at 0.02 m/s [92].

The mean significant wave height (H_s) is 1.59 meters in daily conditions [93], between 4.5–7 meters as the annual maximum [94], and 10 meters in extreme conditions (1/50 yr.) [95]. The mean wave period varies between 4.8 to 6.5 s. (de winter); maximum annual wave period conditions can be estimated based on the wave height and steepness and are between 7.5 – 9.5 s. The waves create a velocity (current) in the water, with lower velocities at higher depths.

$$sop = \frac{H_s}{1,56 T_p^2}$$

Roest (2015) measured current velocities using Triaxys buoys at Gemini wind park at various depths [92]. Measurements near the bed led to a $|U_{average}| = 0 - 0.4$ [ms⁻¹], $|U_{annualmax}| = 0.4 - 0.6$ [ms⁻¹], and $|U_{extreme}| = 0.6 - 0.8$ [ms⁻¹] at a depth of 30 meters [92] [96]. These velocities are much lower than in the shallower parts of the water body.

These velocities can be validated through the following calculations [97]:

$$u_{totaal} = u_{bed} + u_{tidal} + u_{residual}$$

$$u_{bed} = \frac{\omega \cdot a}{\sinh k h}$$

In this calculation, u_{tidal} and $u_{residual}$ are the highest tidal velocities (at flood time) and mean residual velocities.

We chose the following definitions: water depth $h=30$ [m], tidal current $u_{tidal} = 0.05$ [m/s], residual current $u_{residual} = 0.02$ [m/s], gravitational acceleration $g=9.81$ [m/s²], significant wave height $H_s=1.6$ [m], annual max. wave height $H_a=5$ [m], mean wave period $T_z=5$ [s], annual maximum wave period $T_a = 8$ [s]. The wave number [1/m] is determined by:

$$k = \frac{2\pi}{L}$$

The wavelength L [m] can be determined through:

$$L = \frac{g \cdot T^2}{2\pi} \tanh k h$$

The angular frequency [-] in waves is:

$$\omega = \frac{2\pi}{T}$$

The wave amplitude [m] is:

$$a = \frac{H}{2}$$

This leads to an average current of 0.1 m/s and an annual maximum of 0.7 m/s. This is in line with the measurements of Roest (2015) at the Gemini wind park location.

Other characteristics of Gemini wind park that will most likely not influence the test:

Surface temp. range: 3-18 C°

Salinity: 32.5 - 35.0 psu

Average wind speed 10 m/s [98]

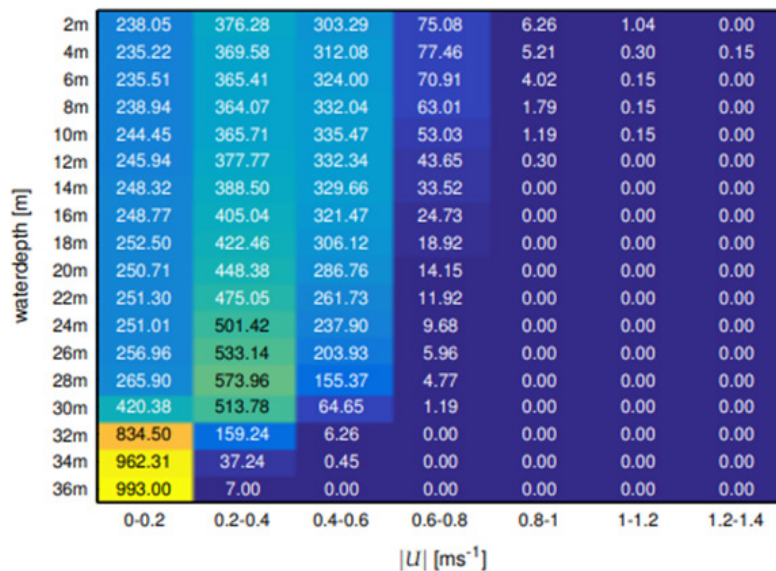

Figure 4.2: Per mille of occurrence %. 1000 means all measurements in that water layer fall within that absolute velocity bin

Borkumse stenen:

The Borkumse stenen is a protected area north of Schiermonnikoog. The local water depth varies between 10 and 30 m. About 70% of this area has a flat bottom, with occasional sand ripples. This bottom exists of silt and clay. About 15% of the area is covered with gravel; about 10 % is covered with stones and boulders. A small part is covered with sand (420 μm) [99]. The gravel and stone bottoms are located in the most shallow areas.

We want to test whether the product also performs on different sediment (than the Gemini sediment type), so a gravel underground will be used to replicate the Borkumse stenen.

The tidal currents in this area are stronger with a mean of 0.06 m/s [100]. Residual currents are 0.2 m/s, similar to the Gemini site.

Current velocity measurements in the general range between 0.27–0.31 m/s at 25 meters depth [101]. The North Sea Observation and Assessment of Habitats estimate the average current to be 0.33 m/s at 1 meter above the sea bed, and 0.94 m/s as the annual maximum [102]. Larsen et al (2003) estimated 1.1 m/s to be the annual maximal current speed [103].

There is little data available on wave heights, therefore we choose the same mean significant wave height (Hs) to be 1.6 m in daily conditions, the same as in Gemini wind park. The annual maximum significant wave height is estimated at 6.5 meter [103]. The wave periods are estimated based on the wave steepness.

We chose the following definitions: water depth $h=20$ [m], tidal current $u_{tidal} = 0.06$ [m/s], residual current $u_{residual} = 0.02$ [m/s], gravitational acceleration $g=9.81$ [m/s²], significant wave height $H_s=1.6$ [m], annual max. wave height $H_a= 6.5$ [m], mean wave period $T_z=5$ [s], annual maximum wave period $T_a = 9$ [s].

For a depth of 15 m (as the gravel occurs in the shallower parts of the area, estimated between 10-20 m), the average daily current can be calculated to be 0.26 m/s, and an annual maximum is calculated to be 2.86 m/s.

Hypotheses:

Expectations regarding product stability

In an attempt to understand the stability, it is necessary to understand which forces can make the product move. There are two approaches possible: the Izbash approach and the Shields approach (Schierreck, 2016). Izbash focuses on the force action due to near bed velocity, while Shields focuses on the average shear stress on the bed. Izbash is useful for rocks (larger things), while Shields is used more for grains (smaller things). We will use Izbash here to estimate the critical flow (even though he does not take water depth into account), as we have to do with a larger object.

$$\Delta = \frac{\rho_{gypsum}}{\rho_{saltwater}} - 1$$

$$\Delta d = 0.7 \frac{u^2}{2g}$$

Following Izbash, we can determine the minimal nominal product diameter. If our product is larger, then it will stay stable. I chose the density of gypsum for this estimation. However, the relative submerged density is needed, as the product will be laying under water on the sea floor.

Izbash predicts the rolling movement of a rock (or product), not sliding or floating.

For a critical flow of 0.13 m/s (the average at 30m depth in Gemini) a minimal diameter of 0.5 mm is needed. This is significantly smaller than our product, so we can predict that the reef tile will not roll at this flow.

	u	d
Gemini average	0.13 m/s	0.48 mm
Gemini annual max.	0.61 m/s	10.65 mm
Borkum average	0.32 m/s	2.93 mm
Borkum annual max.	1.51 m/s	65.28 mm

We can expect the product to be stable in all conditions, except for the annual maximum flow at Borkumse stenen. It has to be remembered, however, that this calculation makes use of the nominal diameter (the nominal diameter is the side of a cube with the same volume as the product considered). My product has an artificial shape, therefore, these are only estimations.

Using Izbash we can also predict at which critical velocity the product would start rolling. For a diameter of 60 mm we can estimate the rolling movement to start at 1.45 m/s. These values might still influence the design, as the designs are not yet fixed!

Expectations regarding sediment transport

We want to estimate at what flow velocities sediment starts to move and when therefore burial of the product is a risk. We can use Shields for determining at what critical flow sediment transport starts, as this is more suited for grain sized material.

$$Re_* = \frac{u_{c*} \cdot d}{\nu}$$

$$u_{c*} = \sqrt{\Psi \cdot \Delta \cdot g \cdot d}$$

$$u_* = Cd \cdot u^2$$

With a sand grain diameter of 210 μm (0.0002 mm) and a constant $\nu = 1.33 \times 10^{-6} \text{ m}^2/\text{s}$, relative submerged density of sand $\Delta = 1.65$, Shields parameter $\Psi = 0.045$ found iteratively, leads to a shear velocity of 0.016 m/s. Recalculated using an estimated hydraulic drag coefficient $Cd = 0.2$ (in turbulent flow) for sand, this leads to a flow velocity of $\sim 0.3 \text{ m/s}$.

This implies that sediment will start to move, as Shields calculates the continuous movement, and that burial could be a large risk with such small grain sizes. For the gravel beds this is much less of a problem, having a larger flow velocity until movement ($\sim 0.8 \text{ m/s}$). It has to be remembered, however, that these are only estimations.

Appendix 8 - Choice of sediment size for flume experiments

Gemini wind park Buitengaats:

Sandy bottom: 0.2-0.5 mm (sand) [36],
Sediment layer height: 5 cm.

Stony bottom (profile: filter layer scour protection):
Ø 10-20 cm rocks (natural crushed granite) [97],
Sediment layer height: one layer of rocks.

Borkumse stenen:

Gravel bottom Ø 16-22 mm (morena split),
Sediment layer height: two layers of gravel.

(Riffen van open zee (H1170, Natura 2000) [99] >> Gravel larger than 8mm),

Results Sheet - Product Positioning

Experiment nr.:.....

Location:

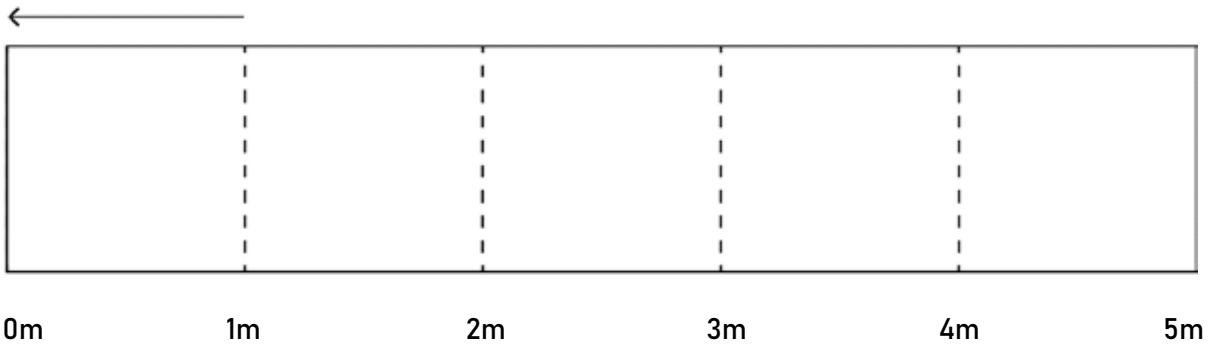

Orientation:

X
Y
Z

Burial:

0%	20%	40%	60%	80%	100%
.....

Touching each other:

.....
-------	-------	-------	-------	-------	-------

Appendix 10 - Calculation of cost-price

Benaming Reef tile		Productieserie		500.000	stuks	per onderdeel
Materiaalkosten		bruto hoeveelheid/product		eenheid	prijs/eenheid	bedrag
halffabrikaat	Calcast 300	0,25	kg	€ 0,45	€ 0,11	
halffabrikaat	drinkwater	0,1	kg	€ 0,00	€ 0,00	
					totaal materiaalkosten	€ 0,11
Bewerkingskosten		capaciteit [stuks/u]	machineuren	uurtarief	machinekosten	
machine 1	100	5000,00	€ 12,00	€ 60.000,00		
					totaal machinekosten	€ 60.000,00
machines als bovenstaand		mens/machine-bezetting	arbeidsuren	mensuurtarief	arbeidskosten	
machine 1	1	5.000,00	€ 18,00	€ 90.000,00		
					totaal arbeidskosten	€ 90.000,00
					totaal bewerkingskosten	€ 150.000,00
Instelkosten serie		insteltijd [u]	uurtarief insteller	mach.uurtarief	kosten	per product
machine 1	10	€ 24,00	€ 12,00	€ 360,00	€ 0,00	€ 0,00
Gereedschapskosten		aanschafprijs	standtijd [stuks]	restwaarde	prijs/eenheid	
matrijs A	€ 500	25.000	€ 0,00	€ 0,02		
subtotalen		€ 500	€ 0,00			
gemiddelde waarde	€ 250					
kapitaalrente	0,0%	rentekosten	€ 0,00	€ 0,00		
					totaal gereedschapskosten	€ 0,02
Algemene toeslagen						
uitval-factor*	1,0%	*afgekeurde producten, zie Kals voor percentages			subtotaal	€ 0,43
overheadfactor**	15,0%	** algemene toeslag voor productiefaciliteiten				
totaal		16,0%				€ 0,07
K _{FI} voor interne calculatie:					Productiekostprijs Reef tile	€ 0,50

Product	Reef tile					
In-huis te vervaardigen	prijs/stuk	stuks/product	prijs per product			prijs per product
Reef tile	€ 0,50	1	€ 0,50			
		1	€ 0,00			
		1	€ 0,00			
		1	€ 0,00			
					totaal vervaardiging	€ 0,50
Inkopen	prijs/eenheid	eenheid	eenheid/product	prijs per product		
inkoopdeel A	€ -	0	€ 0,00			
inkoopdeel B	€ -	0	€ 0,00			
inkoopdeel C	€ -	0	€ 0,00			
inkoopdeel D	€ -	0	€ 0,00			
verpakkingsmateriaal	€ -	0	€ 0,00			
					totaal inkoop	€ 0,00
Assemblagekosten		assemblageserie	10.000			
capaciteit [stuks/u]	machineuren	uurtarief				
montagestation	80	0,00	€ 43,33	€ 0,00		
instellen montagestation	nvt	0,00	€ 43,33	€ 0,00		
handmontageplek	200	50,00	€ 2,50	€ 125,00		
verpakken	20	0,00	€ 2,00	€ 0,00		
					totaal machinekosten	€ 125,00
machines als bovenstaand		mens/machine-	arbeidsuren	uurtarief	arbeidskosten	
montagestation	1	0,00	€ 25,00	€ 0,00		
instellen montagestation	1	0,00	€ 30,00	€ 0,00		
handmontageplek	2	100,00	€ 18,00	€ 1.800,00		
verpakken	1	0,00	€ 18,00	€ 0,00		
					totaal arbeidskosten	€ 1.800,00
					totaal assemblagekosten	€ 1.925,00
						€ 0,19
K _{FI} Productiekostprijs geassembleerd product voor interne calculatie:					Productiekostprijs Reef tile	€ 0,70

Voorbeeldberekening voor de winkelprijs op basis van de fabricagekostprijs (bron: Erik Thomassen).

K _{Ft}	Productiekostprijs geassembleerd product voor interne calculatie:	Reef tile	€ 0,70
F _{OB}	Overheadfactor voor algemene bedrijfskosten*	15%	
F _{OV}	Overhead factor voor verkoopkosten	5%	
F _W	Winstfactor (onvoorziene kosten worden a.h.w. uit de winst betaald)	25%	
	Totaalfactor = product van (elk van deze factoren+1) min 1	50,9%	€ 0,35
K _V	Verkoopprijs af-fabriek (moet je betalen als je product bij de fabriek zelf ophaalt)		€ 1,05
	Marge tussenhandel (bijvoorbeeld: importeur, groothandel, leverancier, distributeur)	30,0%	€ 0,31
	Groothandelsverkoopprijs		€ 1,36
	Marge detailhandel (winkel) is zeer branche- en aanbiedingsafhankelijk, ligt tussen 25% voor een webshop en 300% voor een servicegerichte detaillist in een mooi pand op een A-locatie. Strategie met oog op concurrentie bepaalt de marge.	25,0%	€ 0,34
	Netto verkoopprijs (exclusief BTW)		€ 1,70
	BTW (= Belasting op de toegevoegde waarde, = omzetbelasting)**	15,0%	€ 0,26
	Verkoopadviesprijs, normale winkelprijs		€ 1,96

*) Voordat iets geproduceerd wordt, moet er doorgaans van alles gedaan zijn: niet alleen het ontwerpproces, maar ook bijvoorbeeld prototyping in meerder stadia, gebruiksonderzoek, marktontwikkeling, certificering, octrooiaanvragen en dergelijke. Als dit allemaal in de productprijs verdisconteerd moet worden, kan deze aardig oplopen.

**) hoog tarief = 21%, laag tarief =6% (voeding, boeken), soms ook nog heffingen zoals bijvoorbeeld de wettelijke verwijderingsbijdrage.

Appendix 11 - Dissolution experiment setup and results

There is little literature present on the dissolution of hardened plaster in a body of water, therefore an own experiment was executed. With this experiment, the aim was to make a substantiated estimation of the dissolution of this material.

The dissolution experiment was comprised of determining the dissolution rate of pure cast gypsum plaster spheres (D=30mm) in seawater and tap water, based on the dissolved weight over a time of sixty days. Per water type, the dissolution was tested in five trials. The gypsum plaster mixture was attained by mixing 20 g plaster (MODULAN Modelgips 105) with 12 ml tap water. The spheres were air-dried at room temperature for 24 hours before their application.

Two non-translucent containers filled with 5.6 L tap water or with 5.6 seawater (attained from Wijk aan Zee shore), with the five spheres per container laying 50 mm apart from each other. The wet spheres were weighed after 24 hours, whereafter the containers remained closed and at room temperature. The spheres were weighed every seven days. The control group consisted of five plaster spheres that were remaining outside of the water. After sixty days, all spheres were air-dried for 24 hours and weighed again.

This resulted in the following dissolution graphs:

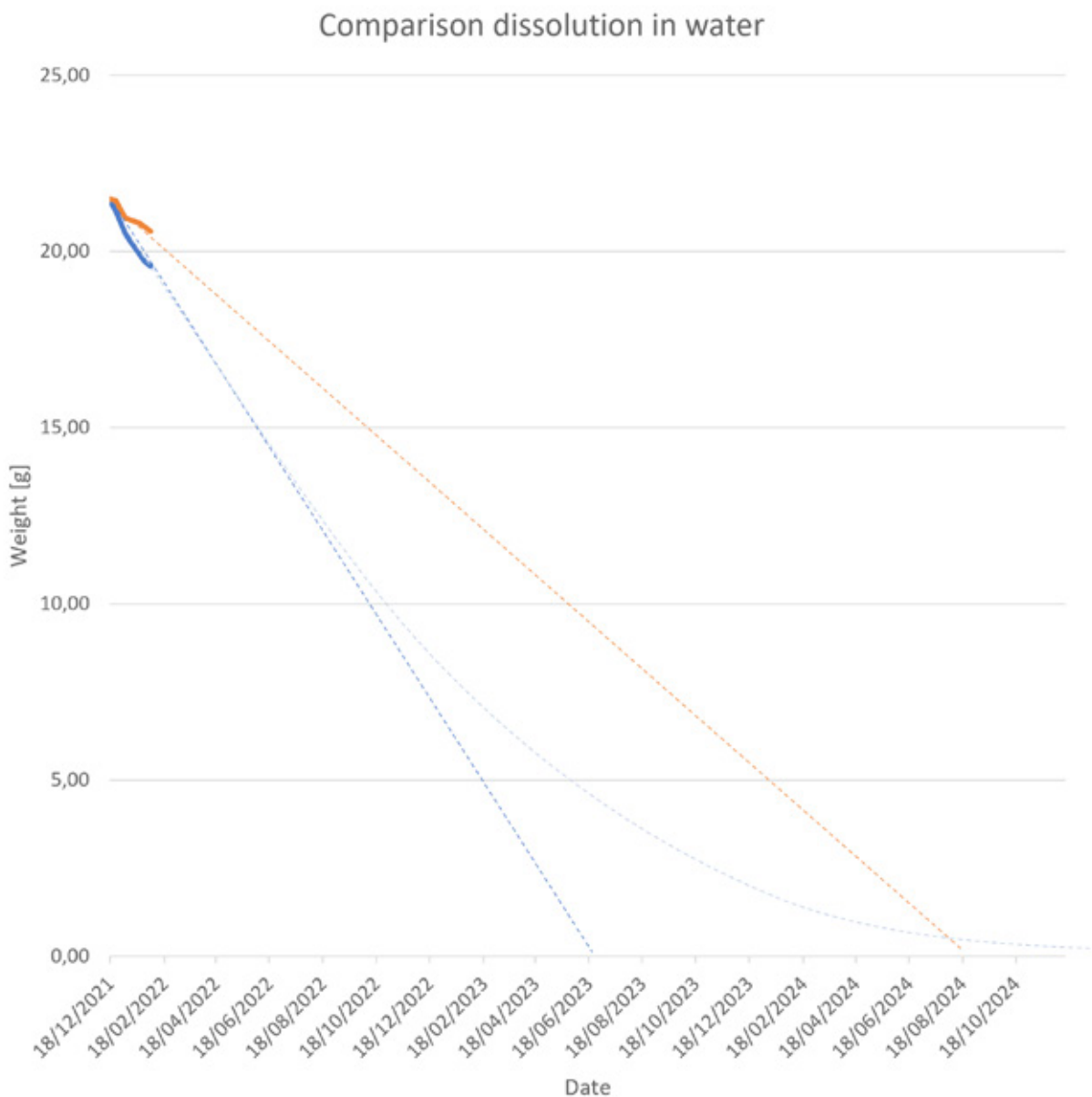

Discussion:

The relevance of the experiment was, after thorough research, found to be very low. This was due to two problems with the test setup.

The first problem had to do with the amount of water: the water can become saturated with the dissolved gypsum if the volume of the body of water is too low [68]. Based on the solubility product of $\text{CaSO}_4 \cdot 2\text{H}_2\text{O}$, five spheres of each ~ 17 g could saturate almost 100 litres of water. The dissolution retards when the saturation equilibrium is reached.

An additional problem is created by stratification in the container, as the spheres were placed on the bottom. When a solid dissolves in quiescent water, material from the solid dissolves and diffuses away, producing a solution near the solid that is denser than the water itself. This dense solution flows downward, and may “pool” on the bottom of the container, creating a layer of solution with a higher concentration of the dissolving material than in the bulk liquid. Therefore, if the dissolving solid is placed on the bottom of the container, it will generate a layer of relatively concentrated liquid that will retard the dissolution rate compared to the solid in a pure bulk solution [71].

A difference in dissolution rate could be observed between the two types of water: the gypsum spheres showed higher dissolution rates in seawater than in tap water. Thompson and Glenn (1994) also observed lower dissolution rates in freshwater than in seawater [71]. Increasing the salinity leads to an increase in ionic strength, which in turn increases the solubility product. However, a higher rate of Ca SO saturation should counteract this.

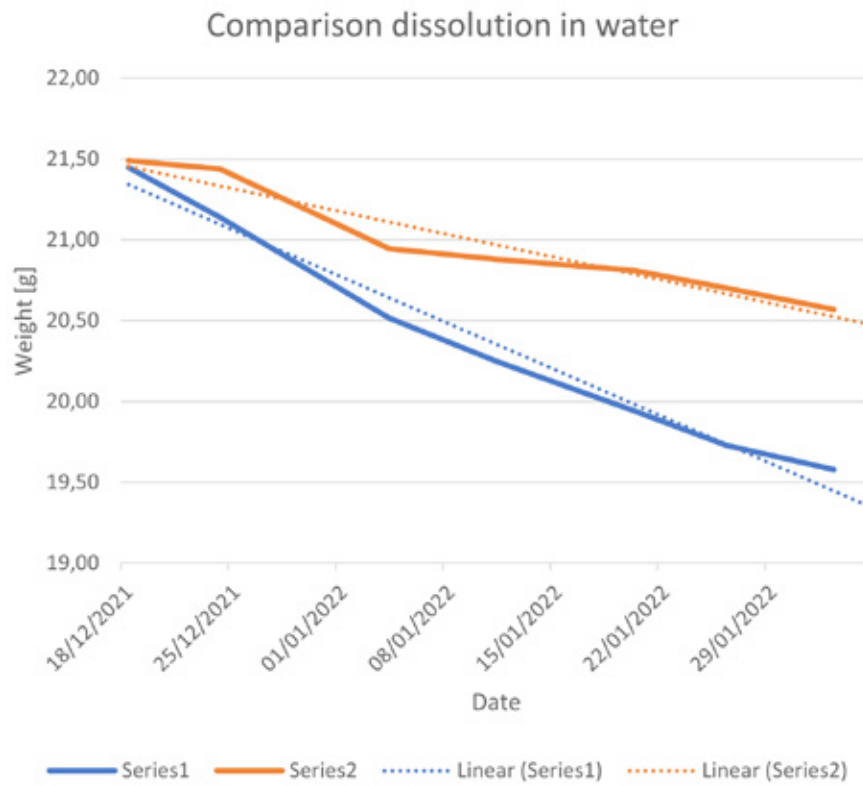

Appendix 12 - Dissolution experiment setup and results

Temperature: -0.006×10^{-5} m/s in k for each -1°C

- Average: 13°C
- Maximum: 18°C

AND

Flow velocity: -0.15×10^{-5} m/s in k for each $+0.1$ m/s

- Average: 0.15 m/s
- Maximum: 0.7 m/s

Author	Value for k	Flow rate	Water type	Temp. ($^\circ\text{C}$)	average	max
Aljubouri & Al-Kawaz, 2007 [67]	$0,0081 \times 10^{-5} - 0,051 \times 10^{-5}$ m/s	0,00 m/s	freshwater	27/28 $^\circ\text{C}$	$1,43 \times 10^{-6}$ * $- 1,86 \times 10^{-6}$ *	$8,18 \times 10^{-6}$ * $- 8,61 \times 10^{-6}$ *
	$0,24 \times 10^{-5}$ m/s	0,08 m/s	freshwater	24 $^\circ\text{C}$	$2,79 \times 10^{-6}$ *	$9,54 \times 10^{-6}$ *
	$0,33 \times 10^{-5}$ m/s	0,14 m/s	freshwater	25 $^\circ\text{C}$	$2,58 \times 10^{-6}$ *	$9,63 \times 10^{-6}$ *
	$0,39 \times 10^{-5}$ m/s	0,19 m/s	freshwater	26 $^\circ\text{C}$	$2,37 \times 10^{-6}$ *	$9,42 \times 10^{-6}$ *
	$0,41 \times 10^{-5}$ m/s	0,24 m/s	River freshwater	16 $^\circ\text{C}$	$2,42 \times 10^{-6}$ *	$9,47 \times 10^{-6}$ *
	$0,50 \times 10^{-5}$ m/s	0,30 m/s	River freshwater	16 $^\circ\text{C}$	$2,57 \times 10^{-6}$ *	$9,62 \times 10^{-6}$ *
	$0,55 \times 10^{-5}$ m/s	0,34 m/s	River freshwater	17 $^\circ\text{C}$	$2,26 \times 10^{-6}$ *	$9,31 \times 10^{-6}$ *
James and Lupton (1978) [104]	$0,14 \times 10^{-5}$ m/s	0.15 m/s	Distilled water	23 $^\circ\text{C}$	$0,8 \times 10^{-6}$ *	$7,85 \times 10^{-6}$ *
Langmuir (1997) [105]	$0,02 \times 10^{-5}$ m/s	0,00 m/s	unknown	unknown	$2,45 \times 10^{-6}$ *	$9,20 \times 10^{-6}$ *
Sabine et al. (2015) [106]	$2,4 \times 10^{-5}$ m/s	0.5-1.5 m/s	Offshore seawater	26-29 $^\circ\text{C}$	$2,79 \times 10^{-6}$ *	$9,84 \times 10^{-6}$ *
Sadeghiamirshahidi & Vitton (2019) [105]	$1,6 \times 10^{-5}$ m/s	0,00 m/s	unknown	14 $^\circ\text{C}$	$1,8 \times 10^{-5}$ *	$2,52 \times 10^{-5}$ *

Appendix 13 - Dissolution in extreme case

